

Table saw CTS-26, L, XL

***Operating manual,
maintenance manual and Safety instructions***



The name CEDIMA® and the



logo are registered trademarks of CEDIMA®
Diamantwerkzeug- und
Maschinenbaugesellschaft mbH.

The information contained in this publication
may change without prior notice.

CEDIMA® does not undertake any guarantee for
this publication.

CEDIMA® does not accept any liability for
errors which may be contained in this publication
nor for any incidental or consequential loss or
damage that may arise in connection with the
delivery, performance or use of the product.

© CEDIMA® Diamantwerkzeug- und
Maschinenbaugesellschaft mbH
Celle/Germany

All rights reserved. No part of this publication
may be reproduced, adapted, stored in a retrieval
system or transmitted in any form or by any
means, electronic, mechanical, photocopying,
recording or otherwise, or translated into a
foreign language without the prior written con-
sent other than permitted under copyright law.

CEDIMA® • Technical Documentation • 2011
Translation of the original operating manual



Contents

	Preface	4
	EC Declaration of Conformity	5
1.	General product information	6
2.	Basic safety instructions	10
3.	Installing and operating the table saw	16
4.	Operating the table saw	25
5.	Care and maintenance	28
6.	Transporting the table saw and longer standing (storage) times	39
7.	Trouble-shooting (what happens if ...?)	40
8.	Electric connection diagram	43
9.	Terms of warranty	44



Preface

Thank you for choosing a CEDIMA® product.

This operating manual is written for skilled personnel and for operators/users instructed by skilled personnel.

The operating manual provides important information on how to use the machine safely, properly and economically. Following the instructions is necessary for your safety, for reducing repair costs and down-times and to maintain reliability and extend the useful life of the machine

Read through this manual carefully before you start working with your new machine.

The manual must be kept close to the machine at all times and must be read and applied in practice by anyone who will be working with or on or handling the machine. The operating manual are to be supplemented by any instructions contained in the regulations of your country concerning accident prevention and environmental protection. Besides the operating manual and local regulations on accident prevention that apply in the user's country and place of use, the user must observe general technical regulations such as the regulations of trade associations on safety and proper working.

This operating manual provides full information as required for the proper use of the machine, but should you feel the need to approach us with any queries, please do not hesitate to contact one of our field representatives, or CEDIMA® directly at:

CEDIMA® GmbH
Lärchenweg 3
D-29227 Celle / Germany

Telephone: +49 (0) 51 41 / 88 54-0
Fax: +49 (0) 51 41 / 8 64 27

e-Mail: info@cedima.com
Internet: www.cedima.com



EC Declaration of Conformity

Manufacturer:

CEDIMA® Diamantwerkzeug- und Maschinenbaugesellschaft mbH,
Lärchenweg 3, D-29227 Celle

List (chart, table), storage of technical documents:

Technical documentation of

CEDIMA® Diamantwerkzeug- und Maschinenbaugesellschaft mbH,
Siedemeierkamp 5, D-29227 Celle

Description of the machine:

Movable table saw **CTS•26, CTS•26 L, CTS•26 XL** mounted to 4 fold- away feet for wet cutting e.g. large-sized tiles, clinker, natural stone (marble) as well as similar abrasive material on a fixed table with diamond saw blades up to a diameter of 250 mm. Swivel cutting head with electric 1,1 kW blade drive motor for bevel cut of up to 45° infinitely variable, guide rail movable. Max. cutting depth 65 mm, max. cutting length 650 mm **CTS•26**, 850 mm **CTS•26 L**, and 1150 mm **CTS•26 XL**. Water supply with electric immersion pump in 20 l bucket or 18 l **CTS•26**, 20 l **CTS•26 L** or 25 l **CTS•26 XL** water container.

Measured sound power level: $L_{WA} = 96 \text{ dB(A)}$,

Guaranteed sound power level: $L_{WA (d)} = 99 \text{ dB(A)}$

Procedure for the evaluation of conformity: RL 2000/14/EG, Appendix V

Herewith we declare that based on the machinery directive 2006/42/EG, Appendix II A of the European Parliament and the Council of the 17.05.2006 the table saw

CTS•26, CTS•26 L, CTS•26 XL as from the year of construction 2010

is compatible with the following directives and standards:

DIN EN 12100-1, DIN EN 12100-2, DIN EN 12418, DIN EN 60204-1, 2000/14/EC.

Regarding electrical hazards, safety objectives according to Appendix I No. 1.5.1 of the machinery directive 2006/42/EC of the low-voltage directive (73/23/EEC followed by) 2006/95/EC have been observed.

Regarding emission of undesired radiation, the machinery directive 2006/42/EC according to Appendix I Nr. 1.5.10 regarding protection, edited in the EMC-directive (89/336/EWG followed by) 2004/108/EC have been observed.

This declaration of conformity will lose its validity as soon as alteration to the machine are made which have not been approved by us!



D-29227 Celle, 27.04.2010

Axel Fischer (managing director)

1. General product information

1.1 Description of the table saw

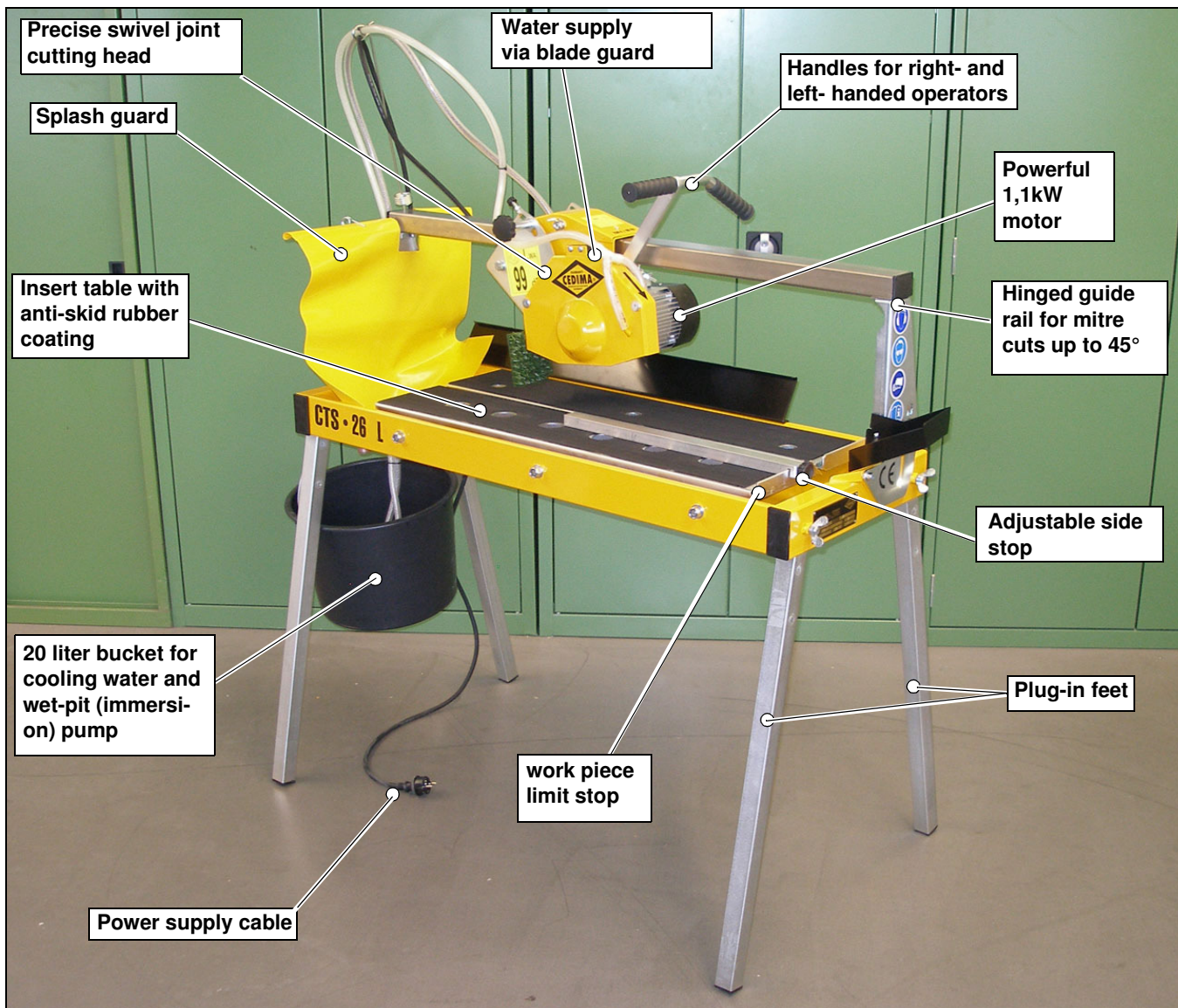

Fig. 1.1 Features of the table saws series CTS•26, shown CTS•26 L

The table saw CTS•26, CTS•26 L, CTS•26 XL is a professional, multipurpose saw (abrasive-cutting-off machine) that can be used for cutting floor tiles, paving stones, marble tiles and similar abrasive material with diamond saw blades in wet-cutting mode.

The saw is characterized by its sophisticated, practice-orientated design:

- The work piece rests on the rubber-coated anti-skid working table while the swivel joint cutting head is pulled along a guide rail during the cutting operation.
- A limit stop with measuring scale as well as an adjustable side-stop ensure the precise alignment of the work piece.
- The work table hanging in the frame can easily be removed for cleaning and transporting the saw.
- A 20 l bucket hanging below the frame collects the cooling water used during the cutting operation.

Table saw CTS•26, L, XL



- tion. This allows the contaminated cooling water to be replaced quickly and easily.
- An electric wet-pit (immersion) pump conveys the cooling water from the bucket directly to the rotating saw blade. Alternatively, it is also possible to put the pump into the water container.
 - The saw is designed to support adjustable mitre cuts up to 45°.

- The plug-in feet, hinged rail and work table can be disassembled (Fig. 1.3), thereby allowing the saw blade to be transported easily to other storeys or onto scaffolds.
- The table saws CTS•26, CTS•26 L and CTS•26 XL vary from each other by different cutting length (650 mm, 850 mm und 1150 mm, Fig.1.1 and 1.2).



Fig. 1.2 Table saw CTS•26 XL



1.2 Technical specifications

	CTS•26	CTS•26 L	CTS•26 XL
Saw blade diameter (max.)	250 mm		
Bore hole diameter	25,4 mm		
Max. cutting depth	65 mm		
Max. cutting length (as blade enters the work piece)	650 mm	850 mm	1150 mm
RPM of the cutting shaft	2770 min ⁻¹		
Electric power supply (blade drive motor, water pump)	230 V / 50 Hz		
Power consumption of the blade drive motor (S6-operation)	8 A		
Drive motor output (S6-operation)	1,1 kW		
Protective system	Blade drive motor IP 55, Water-Pump IPX 8, Switch IP 54		
Contents of water bucket / water container	approx. 18 l / 20 l	approx. 20 l / 20 l	approx. 25 l / 20 l
Power of the water pump	50 W		
Max. conveying rate of the water pump	approx. 11,6 l/min		
Max. Water temperature	35 °C		
Dimensions (length x width x height)	1040 x 480 x 1140 mm	1240 x 480 x 1140 mm	1530 x 480 x 1140 mm
Transport dimensions (length x width x height)	1040 x 480 x 480 mm	1240 x 480 x 480 mm	1530 x 480 x 480 mm
Weight (dry, empty)	58 kg	70 kg	76 kg
Weight with water (bucket or container)	approx. 76 kg to 96 kg	approx. 90 kg to 110 kg	approx. 96 kg to 121 kg
Sound pressure level at the workplace L _{pA} ¹	78 dB(A)		
Sound power level L _{WA} ¹	96 dB(A)		

¹ While cutting operation, higher values are possible!



Equivalent acceleration total value $a_{hv, eq}^2$	< 2,5 m/s ²
Measurement uncertainty K^2	m/s ²

² - The specified values may vary, depending on conditions of operation, (material to be cut, condition of the machine, handling, operator and diamond saw blade being used.

- When determining the daily exposure action value, the actual exposure time must be taken into consideration, which is influenced/reduced by non- productive times! Included in the non- productive times are, for instance, times for handling work pieces, water supply and disposal (handling of cutting residues/slurry), changing tools, connecting and set-up of the machine, visual checks of the machine and its surroundings.

- Measurement uncertainties as per DIN EN-12096

1.3 Scope of delivery

- 1 x CTS•26, CTS•26 L or CTS•26 XL complete with blade drive motor, roller table, splash guard, bucket (water container) and immersion pump
- 4 x Plug-in feet
- 1 x Open ended (jawed) spanner WS 24
- 1 x Hexagon (Allen) key WS 6
- 1 x Hexagon (Allen) key WS 5
- 1 x Adjustable work piece limit stop
- 1 x Plug and
- 1 x overflow pipe for the water container
- 1 x Operating manual
- 1 x Spare parts list

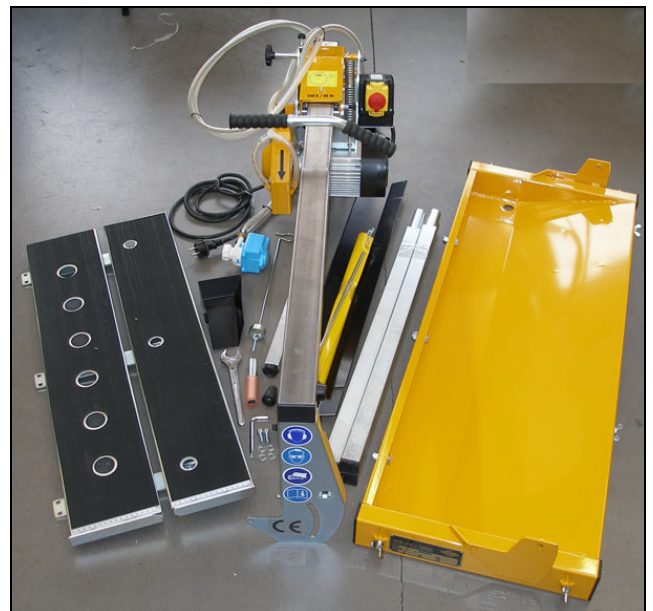

Fig. 1.3 CTS•26 L, disassembled for transport

1.4 Accessories (optional)

Attachable jolly table with anti-skid rubber coating (614 x 586 mm, order no 60 32) for safe seat of bulky (long) work pieces, with workpiece edge and 2 plug-in feet.

When operating with accessories not authorized by CEDIMA®, the resulting damages will not be covered by CEDIMA®!

Respective diamond saw blades are to be found in the actual CEDIMA® price-list.

For special applications please ask CEDIMA® directly.

2. Basic safety instructions



ATTENTION

Pay attention to the entire operating manuals!

Read and pay attention to all operating manuals of the table saw!

2.1 Warning signs and symbols

The following warning signs and symbols e.g. special markings are used in this operating manual:



Note

Special information concerning the economical use. Information appearing after the symbol „Note“ contain information set aside from the usual text.!



ATTENTION

Special information resp. rules to avoid damages! Information appearing after the symbol „ATTENTION“ contain information that must be followed exactly to avoid damages to equipment and material as well as injury to the user or third parties!



DANGER!

Information rep. rules and regulations concerning the prevention of damage to people or property! Information appearing after the symbol „DANGER“ inform you that the non-compliance of the rep. information or policy can lead to injuries to the user or third parties!

Important text is set -off in italics!

Statements concerning the safety are printed in bold and italics!

2.2 Principle of proper use, reasonable foreseeable misuse

- The table saw CTS•26, L, XL, hereafter referred to as the machine, is exclusively designed for wet-cutting of natural stone and artificial stone material using diamond saw blades. Using the machine for purposes other than

those mentioned above is considered contrary to its designed use; in particular the use of the machine with cutting tools other than approved by the manufacturer/distributor is prohibited! The manufacturer/distributor cannot be held liable for any damage resulting from such use! The risk of such misuses lies entirely with the user!

- Operating the machine within the limits of its designated use also includes observing the instructions set out in the operating manuals and complying with the inspection - and maintenance directives!
- The machine has been designed in accordance with state-of-the-art standards and recognized safety rules! Nevertheless, the use may constitute a risk to life and limb of the user or third parties, or cause damage to the machine or the material to be cut!
- The machine may be used in a technically perfect condition in accordance with its designated use, the instruction set out in the operating manual and the relevant national safety regulations and only by safety-conscious persons who are fully aware of the risks involved in operating the machine! Any functional disorders, especially those affecting the safety of the machine must therefore be rectified immediately!

2.3 Organisational measures

- This operating manual must always be at hand at the place of use of the machine and must be accessible to the personnel operating the machine!
- In addition to this operating manual, all other generally applicable legal and other mandatory regulations to accident prevention and environmental protection must be observed! Such obligations may also comprise the handling of hazardous material, provisioning and/or wearing of personal protective equipment!
- This operating manual must be supplemented by instructions covering the duties involved in supervising and notifying special organizational



features such as job organization, work flows or the person entrusted with the work!

- Personal entrusted with the working on the machine must have read the operating manual prior to taking up work! This also applies especially to persons working only occasionally on the machine, e.g. during setup or maintenance work.
- Check, at least from time to time, whether the personnel is carrying out the work in compliance with the operating manual and paying attention to risks and safety-relevant factors!
- For reasons of safety, long hair must be tied back or otherwise secured, garments must be close fitting and no jewellery - including rings - may be worn. Severe injury may result from being caught by moving parts of the machine!
- Wherever required by circumstances or by law, close-fitting personal equipment must be worn (safety glasses, ear protectors, safety boots, suitable safety shoes, suitable protective clothing). Observe the regulations for the prevention of accidents!
- Observe all safety precaution - and warning signs attached to the machine and always make sure that they are in a perfect legible condition!
- In the event of safety - relevant modifications or changes in the behaviour of the machine, stop the machine immediately and report the malfunction to a competent authority/person!
- Do not remove or make inoperative any safety devices the machine is equipped with!
- Never make any modifications, additions or conversions which might affect the safety without the manufacturers/distributors prior consent! This also applies to the installations and adjustment of safety devices as well as to welding and drilling work on supporting structures!
- Damaged or worn parts of the machine must be replaced immediately! Use original (genuine) spare parts only!
- All spare parts and tools must comply with the technical requirements specified by the manuf-

acturer/distributor! This is always the case when using original spare parts!

- Adhere to the legally prescribed preventive maintenance and inspection intervals or those specified in this operating manual!
- In order to carry out care- and -maintenance work, an adequate working environment (accessibility around the machine), an adequate supply of workshop equipment and respective specialized personal is absolutely essential!
- Make known the place of the fire extinguisher and the handling of it!
- Pay attention to the fire alarm and fire prevention rules!

2.4 Selection of personnel

- Any work on and with the machine must be executed by reliable personnel only. statutory minimum age must be observed!
- The machine must be operated or serviced by trained or properly instructed personnel only! Clearly define the individual responsibilities of the personnel for operating, set-up, maintenance and repair!
- Make sure that only authorized persons work on or with the machine!
- Do not allow persons to be trained or instructed or persons taking part in general training course to work on or with the machine without being permanently supervised by an experienced person!
- Work on the electrical system and equipment of the machine must be carried out only by a skilled electrician or by properly instructed persons under the supervision and guidance of a skilled electrician and in accordance with electrical engineering rules and regulations!

2.5 Normal operations of the machine

- Before you start working, make yourself familiar with the surroundings and circumstances of the site, such as obstacles that might impede work, the soil-bearing capacity and the required

- safety measures, e.g. barriers separating the work site from public traffic!
- Place the machine onto an even, stable ground! The standing stability must be assured! Clear the place of work of any obstacles that could impede work!
 - Any safety dubious working on the machine isto be avoided!
 - Make sure that the machine is only used when in a safe and functioning condition! Use the machine only when all protective devices (e.G. guards, noise absorbers, emergency-off devices) are in their intended location and operative!
 - A visual check of the machine is to be carried out at least once during a shift to ensure that visible damages or faults can be recognized! Any changes (including changes in the performance or behaviour of the machine) must be reported immediately to the supervisor! If necessary, stop the machine at once and secure it!
 - Keep to the instructions given by the manufacturer concerning connection to the power, electricity and water!
 - At malfunction or operational changed behaviour, stop the machine immediately and secure it against unintentional restarting! Have the malfunction/disturbance rectified immediately
 - Before starting cutting operations, check the following:
 - The proper condition of the diamond saw blade (no deformations, damages or loss of segments, ...)
 - The diameter of the saw blade permitted by the manufacturer
 - The cutting speed (RPM) of the diamond saw blade permitted by the manufacturer (max. drive speed of the machine)
 - The compatibility of the machine direction of rotation with the diamond saw blade
 - The compatibility of the diamond saw blade with the tool receptacle (centre bore/flange)
 - The secure seat of the diamond saw blade (mount according to the operating manual of the manufacturer with original screws)!
 - In order to prevent the formation of hazardous clouds of fine dust and to improve the service life of the machine, the cutting operation must be carried out in the wet-cutting method!
 - When carrying out wet-cutting, make sure that enough water is supplied to the right places! Make sure enough cooling water is supplied to the cutting line!
 - When working in the dry-cutting mode, make sure that enough ventilation is provided!
 - When carrying out work that may lead to health endangering or explosive substances, e.g. dust or slurry may develop, pay attention to the currently valid local (national) laws!
 - Follow the start up and shut down instructions in the operating manual!
 - The machine may only be started from the position of the operator (CTS•26, L, XL in front of the swivel cut head)!
 - Before switching on the machine assure yourself that no third party can get hurt by the starting machine!
 - The working area of the machine must only be used by the operator! Other persons must be kept out of the range of the machine!
 - Hearing protection must be worn during operation!
 - To be able to intervene at any time in the working process, make sure there is sufficient visibility of the operating range!
 - When working with electric energy from the three-phase- supply- network resp. with hydraulic drive, the direction of rotation of the tool prescribed by the manufacturer must be maintained in order to prevent loosening of the tool!
 - At malfunction stop and secure the machine immediately and have the disturbance rectified at once!
 - Always secure the machine before leaving it and secure it against unintentional moving and restarting!



2.6 Special- and maintenance work on the machine

- Observe the adjustment, maintenance and inspection activities set out in the operating manual, including information on the replacement of parts or assemblies! These activities may be performed by skilled personnel only!
- Brief the operating personnel before initiating special repair or maintenance work. Appoint a person to supervise such activities!
- At all work concerning the operation, adaptation to production requirements, conversion or adjustment to the machine and its safety-oriented devices or any work related to inspection, maintenance and repair, always observe the start-up and shut-down procedure described in the operating manual as well as the instructions on maintenance activities!
- Maintenance and repair work may only be carried out if the machine is placed onto a level and solid ground and secured against inadvertent movement!
- Has the machine been completely shut down for maintenance and repair work, it must be secured against inadvertent restarting!
- When using lifting gear for replacing individual parts or large assemblies, make sure that these parts or assemblies are carefully attached to the lifting gear and secured in place to avoid hazardous conditions. Use only suitable and technically perfect lifting gear and suspension systems with adequate lifting capacity! Never work or stand underneath suspended loads!
- The fastening of loads and instructing of crane-industrial truck operators should be entrusted to experienced persons only! The instructor must be within sight of the operator or keep in speech communication!
- Before performing any maintenance/repair work, clean the machine, especially the connections and screwed joints and remove any oil, dirt and preservative agents! Use lint-free cleaning rags!

- Before cleaning the machine with water or other cleaning agents, cover up or tape up all openings which-for safety and functional reasons, must be protected against the ingress of water/steam/cleaning agents! special care must be taken with bearings, electric motors and electronic systems! after cleaning, make sure to remove all covers/tapes from the openings!
- After cleaning, check all cables and hose connections for leaks, loose connections, chafe marks and damages! Have any defects rectified immediately!
- Always retighten any screwed connections that had been loosened during maintenance/repair work!
- Any safety devices removed for set-up, maintenance and repair work purposes must be refitted and checked immediately upon completion of the set-up, maintenance and repair work!
- Avoid any operation that might affect the stability of the machine! Always keep a sufficient distance from edges of excavations, ditches and slopes!
- Before leaving the machine, always secure it against unauthorized use!
- Make sure that all process materials and replaced parts are disposed of safely and with minimum environmental impact!
- Check all pipes, hoses and screwed joints for leaks and visible damages at regular intervals! Clear any defects immediately or have the defect rectified immediately!

2.7 Information concerning handling electric energy

- Pay attention to the relevant national regulations, similar the german DIN/VDE regulations!
- Electric connections must always be kept free of dirt and moisture!
- Switch off the machine immediately trouble occurs in the electric power supply!
- Only use rated fuses with the correct current intensity/Ampere! Switch off the machine immediately!

diately there is a disturbance in the electric power supply!

- Make yourself familiar with the prescribed safety distances!
- Work on electric systems or equipment may only be carried out by a qualified electrician or by properly instructed persons working under the supervision of a qualified electrician and in accordance with the applicable electro-technical engineering rules!
- The power supply to parts of the machine, on which inspection, maintenance or repair work is to be carried out, must be cut off (check for stress-/current-free connection)!
- The electric equipment/connections of the machine must be inspected and checked at regular intervals. Any defect, such as loose connections or scorched cables must be rectified immediately!
- If it is necessary to carry out work in the vicinity of live parts, a second person must be present to cut off the power supply in case of an emergency by actuating the emergency-off button or the main power switch! Secure the working area with a red-and-white safety chain and warning signs!
- When work has to be carried out on high-voltage components, switch off the power supply, disconnect the concerned parts from the power supply, connect the supply cable to earth and short-circuit the components, e.g. capacitors with a grounding rod!
- Mobil electric operating equipment and connection cables with plugs as well as extensions and unit connecting cables with plug-connectors are, if used, to be checked for proper conditions at least every 6 months by an electrician or a person trained in electronics using suitable tools!
- Protective devices with fault-current protection units used in nonstationary equipment must be checked for correct operation at least once a month by a properly instructed person!

- Fault-current- and fault-voltage protective units must be checked for correct operation by actuating the testing facilities:
 - once every working day in case of mobile equipment,
 - at least every six months in case of stationary equipment!

2.8 Gas, dust, steam, smoke

- Welding, grinding and sanding work on the machine may only be carried out when it has been explicitly allowed (e.g. there could be a risk of fire or explosion)!
- Make sure that the ventilation is sufficient and remove all dust and flammable material from the vicinity of the machine and its surroundings before welding, grinding, sanding or using a flame on the machine (risk of explosion)!
- When working in small surroundings or narrow rooms, pay attention to national rules that may exist!
- Combustion engines must be operated in sufficiently ventilated rooms! Never let the motor run in insufficiently ventilated or cramped rooms! The exhaust fumes contain poisonous carbon monoxide! Ventilate the exhaust fumes from the work place and provide sufficient ventilation!
- Check all pipes, hoses and screwed joints regularly for leakage and visible damage! Clear any fault immediately/have any fault removed immediately!

2.9 Noise

- The noise absorbing devices must be in their proper protective places during the operating of the machine!
- Wear the prescribed personal ear protection (according to the valid accident prevention laws/health- and safety at work)!



2.10 Lighting

- The machine has been designed for operating in daylight only! The operator must make sure that adequate lighting is provided in unlit areas!

2.11 Information about the handling of fluids and lubrication

- When handling pressurized fluids, lubricants or preservation agents (hereinafter referred to as fluids or lubricants), follow the safety instructions that are relevant to the respective product!
- Avoid any prolonged skin contact with fluids or lubricants and your skin! Carefully clean your skin to remove all fluids or lubricants adhering to it!
- Be careful when handling hot fluids or lubricants! Risk of serious injuries or burns! Especially when handling fluids or lubricants with temperatures exceeding 60 °C make sure to avoid contact between the fluid and your skin!
- If fluids or lubricants have come into contact with your eyes, rinse your eyes with clean drinking water and consult a doctor!
- spilled fluids or lubricants must be removed immediately using binding agents!
- Operating fluids or lubricants may not seep into the ground or into the public sewage system!
- Used fluids or lubricants must be collected, stored and disposed of properly!
- Follow all relevant legal instructions and provisions regarding the handling and disposal of fluids or lubricants! In case of doubt, contact the competent authorities for detailed information!

2.12 Transporting the machine

- Transporting the machine using lifting gear is not allowed!
- Before moving the machine, make sure the main plug is unplugged and all movable parts are locked securely!
- Always disconnect the machine from its mains supply even when performing minor relocations!

- When carrying out loading/unloading operations only use load suspensions with sufficient load-bearing capacity!
- Only use transport vehicles with sufficient load-bearing capacity!
- secure the load carefully! Use suitable fastening points for fastening!
- The diamond saw blade must be dismantled for transport!
- Before loading the machine or its components, secure the machine/components with protective devices included in the delivery against unintentional changes in position! Place suitable warning signs on the machine or its components! before installing or using the machine again, remove such devices or protective material!
- Before transporting/moving the machine, check the secure attachment of the devices to prevent accidents!
- Parts that had to be removed for transporting the machine must be remounted and fixed carefully!
- The re-commissioning procedure must be strictly upheld according to the operating manuals when re-assembling operating the machine!

3. Installing and operating the table saw



Note:

Read the operating manual carefully!

Before you start operating the table saw, read and pay attention to the operating manual and safety instructions!

3.1 Checking the delivery

Please make sure that no part of your CEDIMA® table saw CTS•26, L, or XL is missing or damaged! The scope of the delivery can be found in chapter 1.3.

3.2 Information concerning set-up of the table saw



DANGER!

Risk of injury! Only carry out set-up work when the machine is at standstill! Disconnect the machine from its mains power supply and secure it against unintentional re-starting!



Switch OFF the table saw and pull the mains power plug!



ATTENTION

The complete weight of the table saw is depending on model/design at least 58 kg and must be lifted (according to the employers liability insurance association) with lifting gear!

- Insert the 4 plug-in feet from below into the frame and secure them against dropping out using the wing screws. Tighten the wing screws up to the touch (Fig. 1.1 and 3.1).



Fig. 3.1 Plug-in feet mounted



Note:

Pay attention to the correct position of the plug-in feet!

The plug-in feet spread on the ground!

- The table saw must be placed level and horizontally onto stable ground!
- Place the table saw in such a way, that it causes neither hindrance when being operated nor danger to personnel and/or third parties!
- Place the upper part vertically on to the seat/holder on the frame (water container) and secure with the respective screws, washers and star-grip screws (Fig. 3.2 and 3.3)!

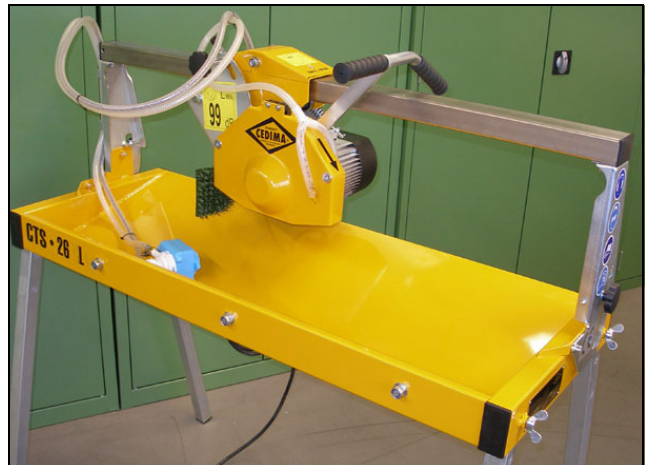

Fig. 3.2 Upper part mounted



DANGER!

Risk of jamming or squeezing!

Pay attention to your hands and fingers!

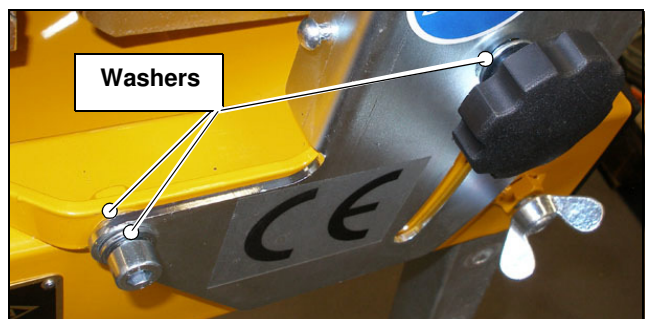

Fig. 3.3 Upper part connecting elements

- Place the work-table onto the receiving frame (water container, Fig. 3.4, 3.5)!



Fig. 3.4 Work table inserted



Note:

The work table can be moved by one bore (Fig. 3.5)!



Fig. 3.5 Work table receiving on the frame

- Mount the lateral splash-guard with the wing screws (washers) onto the frame (Fig. 3.6).

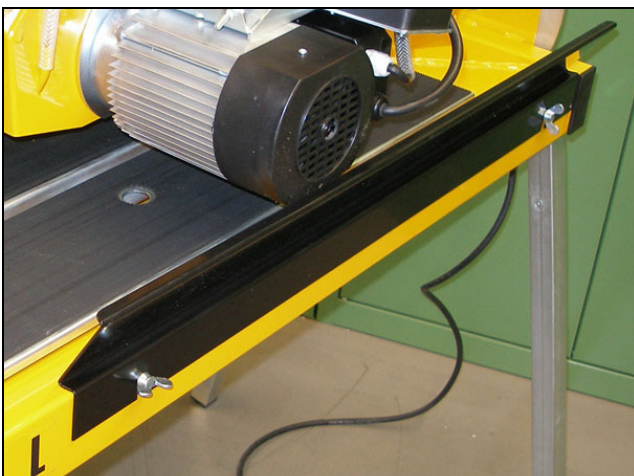

Fig. 3.6 Lateral splash guard mounted

- Hook in the front splash guard (Fig. 3.7).

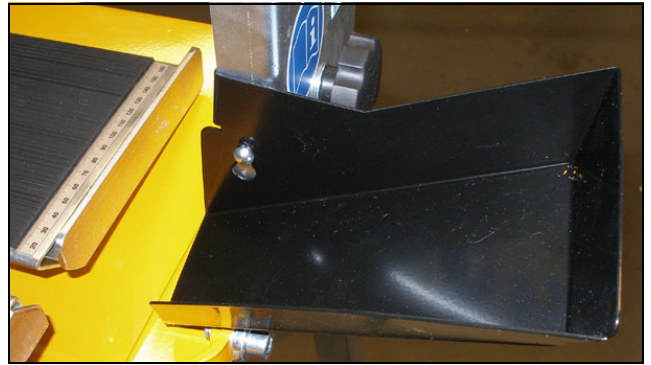

Fig. 3.7 Front splash guard attached

- Insert the cable- and hose holder, with spring to the rail, and attach the cable as well as the water hose with sufficient play (Fig. 3.8).



Fig. 3.8 Cable- hose holder inserted, cable- and water hose attached

- Verify that the swivel cutting head is free to move. For that purpose, loosen the quick-release handle at the cutting head (Fig. 3.9) and move the cutting head up and down!

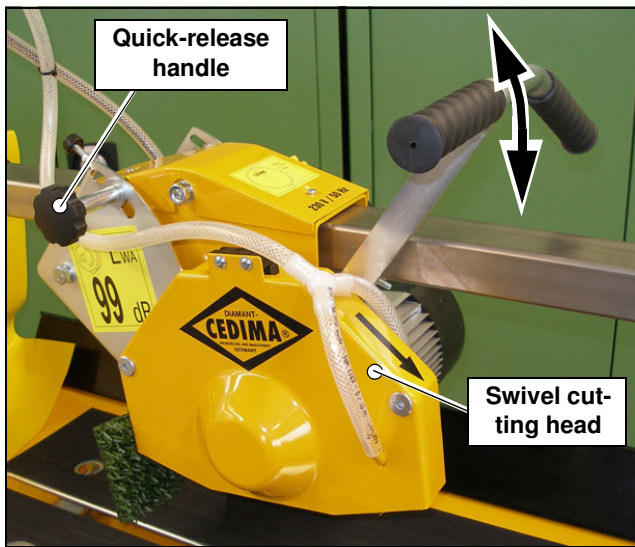

Fig. 3.9 Swivelling the swivel cutting head

- Verify the easy movement of the carriage on the guide rail. For that purpose, pull the detent pin on the guide carriage and turn by 90° (Fig. 3.10 and 3.11).



Note:

Now the guide carriage is free to be moved!

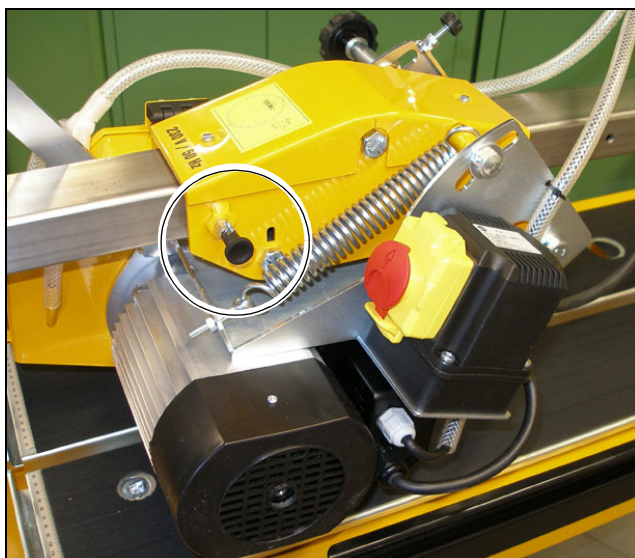

Fig. 3.10 Detent pin on the guide carriage

- Mount the splash guard with the holding rod and secure with the fixing screw (Fig. 3.12 and 3.13).



Fig. 3.11 Position of detent pin: out of function, snap position, locked into place

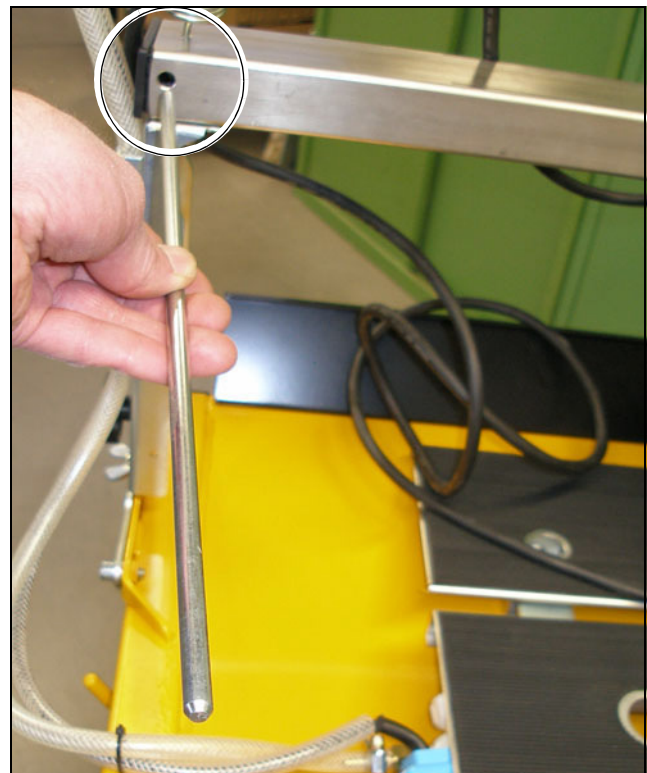

Fig. 3.12 Rod for splash guard



Fig. 3.13 Splash guard mounted

3.3 Information regarding electric connections



DANGER!

Risk of injury due to electric short circuit!

Connections must be made via a socket outlet with grounding contact installed according to regulations. Only that way the protective grounding required for safety reasons is assured! The connecting socket (power outlet) must be protected by a FI or DI switch fault-current breaker!



ATTENTION

Make sure that the table saw is switched off before you connect it to the main power supply!



ATTENTION

Carry out the electric connection properly!

Work on the electrical system or equipment may only be carried out by electricians or trained staff under the direction and supervision of an electrician in accordance with the local electrical engineering regulations!

For use on a construction site the equipment must be connected to the main power supply in accordance with the german DIN VDE 0100, § 55a or similar the country-regulations!

Pay attention to the relevant safety instructions for operating electrical systems, e.g. BGV A3 of the BGFE (employers liability insurance association)!

Pay attention to the relevant german VDE-regulations or similar country-regulations and relevant norms/standards e.g. EN 60 204-part 1!

All electrical connections must be free of moisture!



Note:

Check for possible losses of power in the supply cable!

- Never use a cable-drum while the cable is still wound onto it as this can cause loss of power at the machine!

- Do not exceed a cable length of 50 meters as this could causes loss of power at the machine!

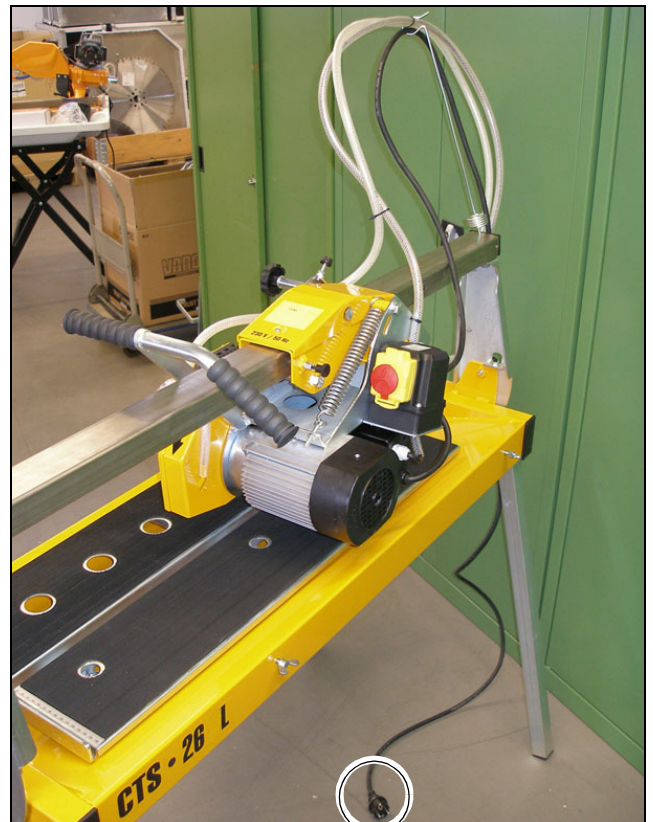

Fig. 3.14 230 V / 50 Hz power supply cable

3.4 The main switch

The main switch (Fig. 3.15) switches the immersion pump together with the blade drive ON and OFF!



Fig. 3.15 Main switch with emergency-stop button

- To switch ON the pump and motor, open the yellow lid with the red emergency-stop button and press the green button (Fig. 3.16)!

- Push the red button (Fig. 3.16) to stop the saw!

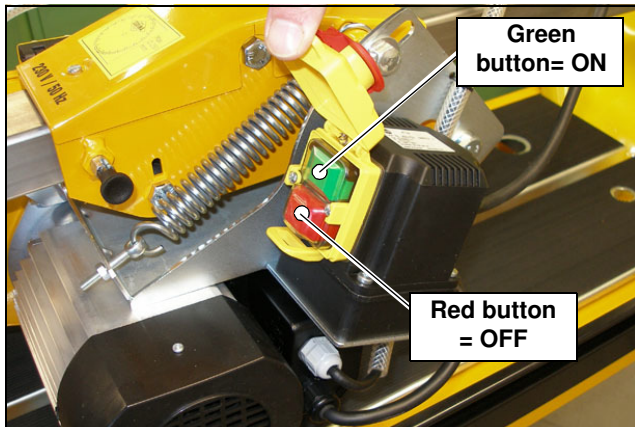

Fig. 3.16 Buttons to switch ON/OFF the saw

- While the saw is being operated, the buttons are covered by the flap (Fig. 3.15). This allows the operator to quickly stop the saw by pushing the emergency-OFF button in the event of danger or faulty conditions. To unlock the red emergency-stop button, push the button upwards until the lid springs open!

3.5 The immersion pump

The electric immersion pump, which conveys the necessary cooling water through hoses to the saw blade, can be put into the bucket (Fig. 3.17) or into the container (Fig. 3.18). When putting the pump into the water container, be sure to plug the drain hole (Fig. 3.19).



Fig. 3.17 Immersion pump in the water container, overflow pipe inserted

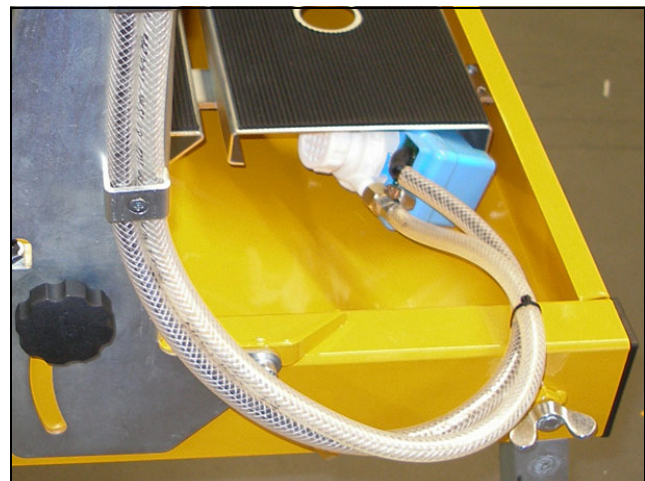

Fig. 3.18 Immersion pump in the water container



Fig. 3.19 Drain hole in the water container (with plug)

There are 3 possibilities for optimal water guidance:

a) Without bucket:

The pump is placed inside the filled water container. The drain hole must be closed with the drain plug. The slurry stays in the water container and must be pumped off regularly.

b) With bucket:

The pump is inserted into the filled water container. The drain hole in the water container must be kept open. In this variation, a great deal of the slurry flows into the bucket, which has to be cleaned regularly.

c) With bucket and water overflow pipe:

The water overflow pipe must be inserted into the drain hole of the water container. The pump is placed in the bucket. Water container and bucket are filled with water.

In this variation, a great deal of water stays in the bucket. The pump stays in the clean water of the bucket and so has longer working life. The water container must be cleaned regularly!



Note:

Due to the watertight housing of the immersion pump, repair works on the electric parts are not possible!

A pump sieve (screen) serves as protection of the pump from coarse dirt particles from the water.

For instructions on how to clean the pump, please refer to sect. 5.8.2!



Note:

To protect the water pump (in the water container) from slurry, the water must be changed repeatedly!



ATTENTION

Never allow the immersion pump to run dry!

The electric immersion pump must never run dry, as this would cause an overheating and destruction of the pump. The pump, especially the suction (inlet) filter must always be completely covered by water. Refill the water bucket/ watercontainer in due time to ensure that the pump will not run dry.



ATTENTION

Prevent the cooling system from freezing!

To prevent the immersion pump and the cooling system from freezing, drain the water after each use and, in case of hard frost, even before longer breaks!

3.6 The blade drive motor

The blade drive motor has been provided with an overload -e.g. thermal cut-out which turns OFF the motor when overloaded or overheated! After waiting a short while, the motor of the table saw can be restarted.



Note:

Avoid overload-switch OFF of the blade drive motor!

See section 7.1!

3.7 The diamond saw blade



DANGER!

Risk of injury! Set-up work must only be carried out when the machine is at a stand-still! Disconnect the table saw from the main power supply and secure against unintentional restarting



Switch the table saw OFF and pull the power supply plug!

3.7.1 Choosing the right kind of saw blade



ATTENTION

Only use approved diamond saw blades!

The blade shaft cutting speed has been explicitly designed for cutting with diamond saw blades.

Under no circumstances may saw blades designed for wood- or metal cutting be used!

The table saw is designed exclusively for the cutting of natural or synthetic stones!

The table saw is designed for the use of diamond saw blades with diameters of 250 mm! Saw blades with larger diameters may not be installed in the table saw!

The blade shaft speed of the table saw is intended to provide optimum conditions for cutting with the CEDIMA® diamond saw blades.

Choose the correct type of saw blade for the material to be cut and the required cutting depth!

Ask the CEDIMA® customer service for detailed information about the different types of diamond saw blades.



Note: No guarantee in case of improper use!

If the CEDIMA® diamond saw blades have been used incorrectly/improperly, the guarantee becomes invalid. Complaints concerning the diamond saw blades can only be accepted if at least 20 % of the diamond segments remain!



Note:

Re-sharpen blunt diamond saw blades!

Diamond saw blades have been designed to be self-sharpening in operation. However, they can become blunt through frequent cutting in hard material that is only slightly abrasive. Blades can be re-sharpened by cutting in an abrasive material such as lime sandstone.

3.7.2 Installing the saw blade

1. Loosen both sleeve nuts on the lid of the blade guard with the 5 mm hexagon socket (Fig. 3.20) and open the lid of the blade guard (Fig. 3.21).



Fig. 3.20 Round nuts on the lid of the blade guard



Fig. 3.21 Lid of the blade guard open

2. Loosen the cutting shaft nut with an WS 24 open-ended spanner (lefthand thread), block the cutting shaft with the WS 6 hexagon (Allen) key from turning (Fig. 3.22).

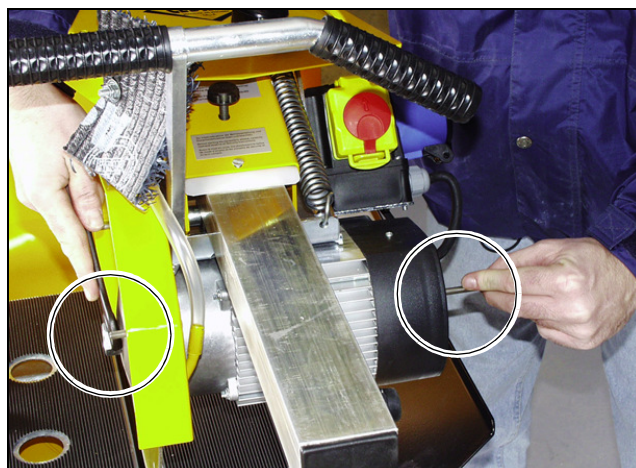

Fig. 3.22 Loosening the cutting shaft nut by counter pressure of the cutting shaft

3. Remove the blade pressure flange (Fig. 3.23).

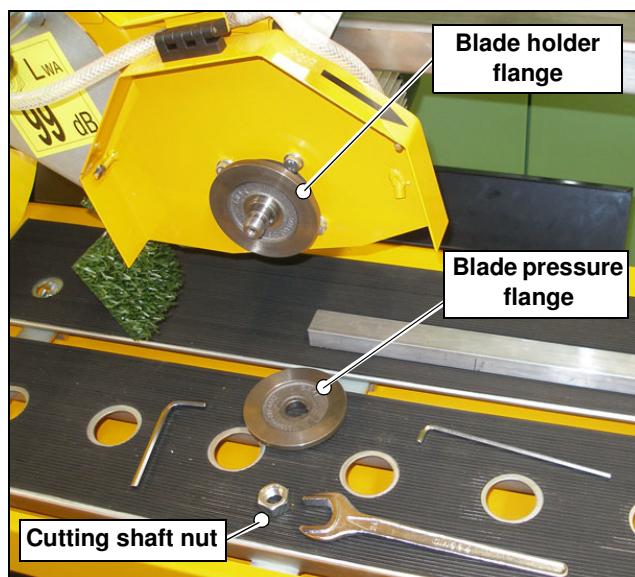

Fig. 3.23 Blade guard opened

⚠ ATTENTION
Check the blade holder and saw blade for proper condition!

The contact area between the saw blade holder assembly and the diamond saw blade must be kept in clean condition to ensure that the blade can be mounted properly!



Never use damaged or untrue saw blades or blades with missing diamond segments!

4. Install the diamond saw blades on the support flange ensuring the correct sense of rotation. The sense of rotation of the cutting shaft is marked by an arrow on the blade guard (Fig. 3.24).



Fig. 3.24 Sense-of-rotation arrow on the blade guard



Note:

Determine the correct sense of rotation!

If the arrow on the diamond saw blade blade is not visible, the cutting direction of the saw blade can be determined in the following way: A “tail” forms behind each diamond particle during cutting and the diamond particle is always at the front in relation to the direction of rotation (Fig. 3.25).

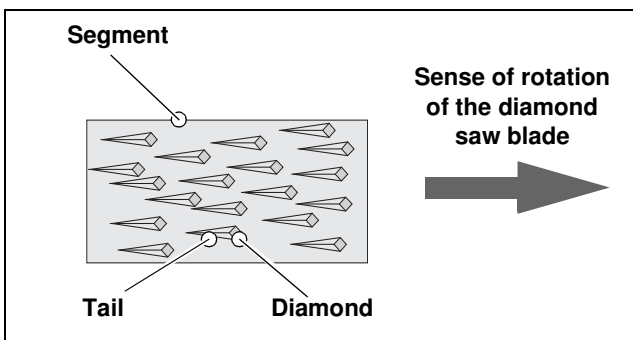

Fig. 3.25 “Tail forming” behind the diamonds

5. Install the blade (pressure) clamping flange.
6. Re-tighten the cutting shaft nut (left-hand thread). Use the hexagon (Allen) key to block the cutting shaft from turning while tightening the nut.
7. Lightly turn the installed saw blade by hand and check for true running by visual inspection.
8. Check the true running by visual inspection in the operation mode! Let the diamond saw blade (the blade drive motor) restart and then turn it OFF immediately



DANGER!

Risk of injury due to insufficient saw blade tensioning and “flapping” diamond saw blade!

A saw blade with insufficient tensioning is noticeable by untrue- flapping run!

9. Re-mount the blade guard!



DANGER!

Operating the machine without the blade guard is not allowed!

3.8 The depth stop



DANGER!

Risk of injury! Carry out set-up work while the saw blade is at a standstill! Disconnect the table saw from the main power supply and secure it against unintentional re-starting!



Switch OFF the table saw and pull the main power plug!



ATTENTION

Set the depth stop to 3 mm!

In order to prevent damage to the table or the table saw, the depth stop must be set in such a way, that the diamond saw blade penetrates approx. 3 mm into the table (measured from the top face of the table, see Fig. 3.26).

To set the depth stop, proceed as follows:

1. Mount the diamond saw blade!

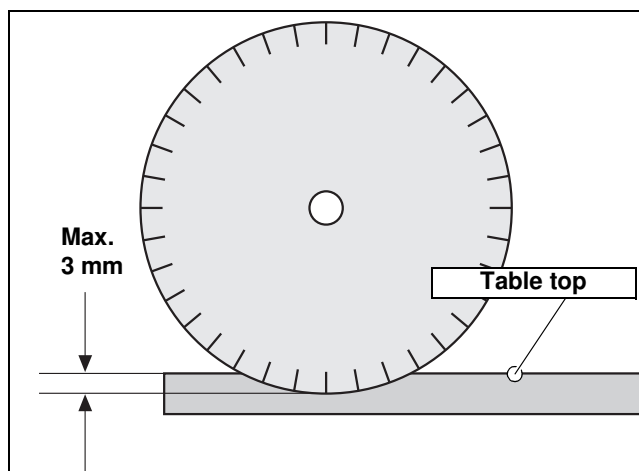

Fig. 3.26 Setting the saw blade to the required depth

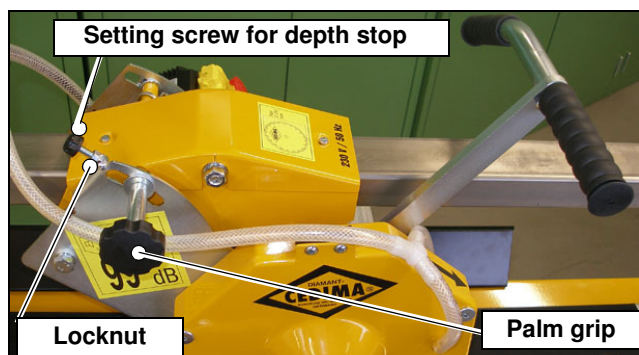

Fig. 3.27 Setting the depth stop

2. Keep hold of the swivel cutting head by the holder (grip) and loosen the palm grip (Fig. 3.27) on the swivel cutting arm!
3. Lower the cutting head with the mounted saw blade to the desired depth setting of 3 mm (Fig. 3.26) and retighten the palm grip!
4. Use the setting screw and locknut (Fig. 3.27) to secure the depth stop!

3.9 Mitre cut adjuster



DANGER!

Risk of injury! Set up work may only be carried out when the machine is at a standstill! Disconnect the table saw from the mains power supply and secure against unintentional restarting



Switch OFF the table saw and pull the main power plug!

The CTS•26, L, XL is equipped with a hinged guide rail (superstructure) for mitre cuts (angle cuts, Fig. 3.28).

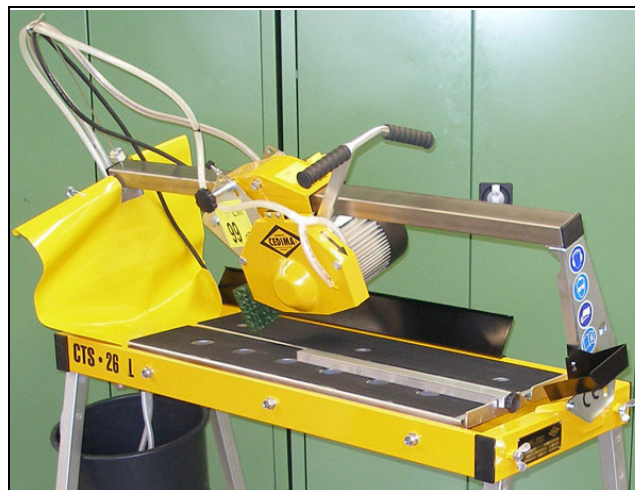

Fig. 3.28 Guide rail for mitre cuts, swivelled

To swivel the guide rail, lightly loosen the palm grip and, if necessary, the hexagon socket screw, at both front sides of the saw (Fig. 3.3) and set the rail to the desired angle. Firmly retighten the palm grip and hexagon socket screw again.



Note:

Set up the mitre(angle) cut with a protractor!

3.10 Optional accessories to the table saw

3.10.1 Auxiliary table

For safe guidance, seat of larger (longer) work pieces, an auxiliary table is available, that can be hinged to the table saw (Fig. 3.29).



Fig. 3.29 Auxiliary table, hinged (angle stop of the table saw attached to the auxiliary table)

4. Cutting operation

After you have made yourself familiar with the components of the table saw, the machine has been set up properly, the bucket and/or water container are filled with water and the electrical connections are established in accordance with the relevant safety regulations you may now begin with the cutting operation.



DANGER!

Risk of injury due to rotating saw blade!
When the table saw starts, the cutting shaft e.g. the saw blade also starts to turn straight away!

Make sure nobody is standing staying in the danger area during start-up (especially in front or behind the cutting direction/saw blade)!



Note:

pay attention to the preceding chapters and sections, especially the safety chapters!



ATTENTION

Always wear personal protective clothing!

The following protective equipment according to regulations:



Respective hearing protection according to noise- and vibration occupational safety!



Wearing eye protectors!



Wearing protective (safety) gloves!

Depending on the respective operational conditions, wearing of further protective equipment may become necessary!



ATTENTION

Lift the diamond saw blade off the material to be cut to be able to start the table saw without danger and trouble free!



ATTENTION

Always use cooling- and rinsing water!

To cool the diamond saw blade and to prevent the forming of health- and endangering hazardous fine dust, the table saw may only be used in the wet cutting mode!



Note:

The water pump starts immediately the table saw is switched on! The pump, especially the suction sieve, must always be covered by water!

- When cutting, the operator stands on the right front face of the table saw and holds the right, if necessary the left hand on to the handle of the swivel cutting arm (Fig. 4.1).

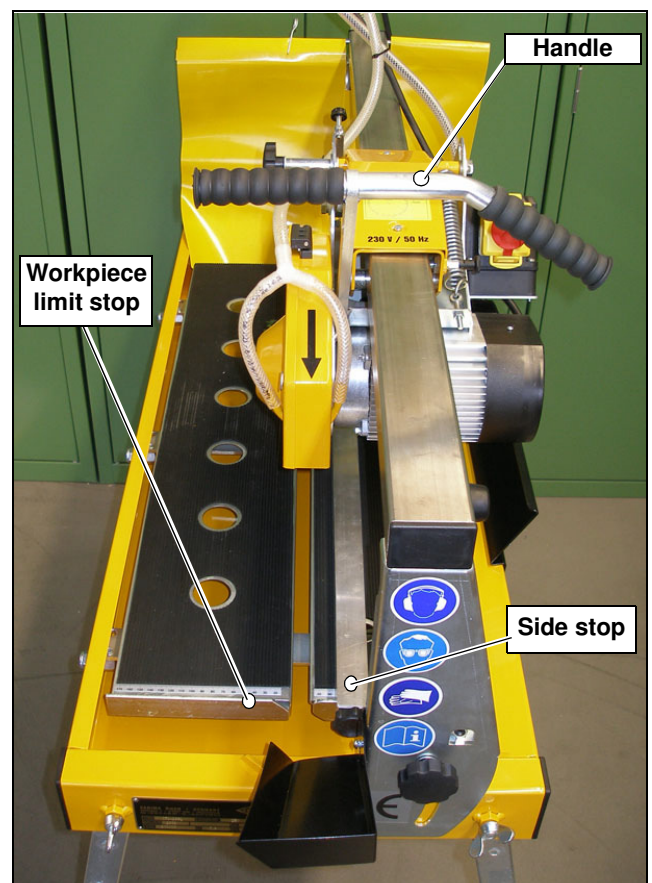

Fig. 4.1 View from the operators stand at the table saw

- The work piece is placed onto the work table and is kept with the respective hand in such a

way, that it is firmly fixed on the adjustable side- and workpiece limit stop (Fig. 4.1).

- Always switch OFF the table saw before you leave the machine, even in case of a short break.
- After finishing cutting operations prevent accidental restarting of the saw by pushing the emergency stop button and unplugging the power cable.

4.1 Cutting at constant depth

When cutting at constant depth, the cutting head is pulled against the workpiece.

Before you start cutting, set the cutting head to the desired fixed cutting depth (cf. par. 3.8). Then use the handle to pull the cutting head slowly and uniformly along the guide rail and across the work piece (Fig. 4.2). Push the cutting head fully back after you finished the cut.

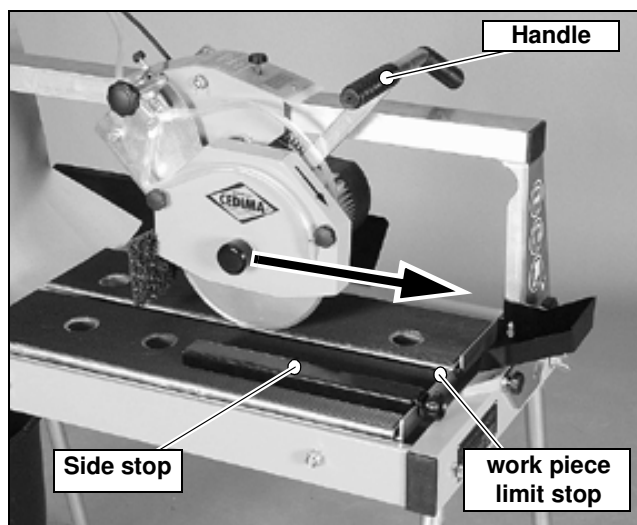

Fig. 4.2 Cutting at constant depth

4.2 Cutting with swivel cutting method

For easier cutting at greater cutting depth, the so-called “swivel cutting method“ is recommended. This method prevents wear of the diamond saw blade and does not overload the motor. When using the swivel cutting method, the swivel cutting head is not fixed with the clamping screw to a predefined cutting depth but can be moved freely.

The swivel cutting head is held down by the respective handle over the work piece ① and moved to- and -fro across, while slightly pressed down the cutting head and lifting it upwards when pulled back ② (Fig. 4.3).

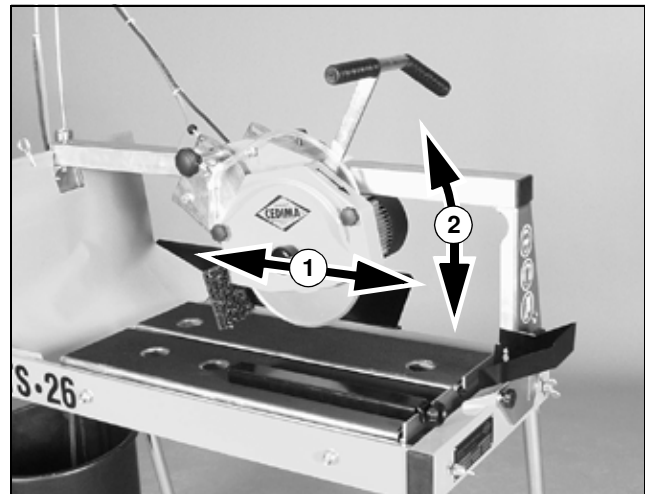

Fig. 4.3 “Swivel cutting method“

4.3 Overload protection of the blade drive motor

The diamond saw blade (blade drive motor) is protected by a motor protection switch (thermo switch). At motor overload, it will switch OFF the motor! The motor will come to a standstill! After waiting a short time, the motor e.g. the table saw can be restarted, see sections 3.6 and 7.1.

4.4 Changing the diamond saw blade

The diamond saw blade must be changed when:

- the diamond segments have completely worn away,
- when the material to be cut changes.

The diamond saw blade must definitely be changed when:

- it is running untrue
- the diamond segments are damaged or have broken off.

Mount the new diamond saw blade as described in sect. 3.7.2!



4.5 Work to be carried out after operation



DANGER!

Risk of injury! Carry out set-up work on the machine! Disconnect the table saw from the main power cable and protect against unintentional restating!



Switch OFF the table saw and pull the main power plug!

- Remove the dirty water from the water bucket, water container
- Remove the slurry from the bottom of the water container
- Rinse the water pump with clear water to avoid blocking the pump wheel due to slurry sediments
- Carry out care- and maintenance according to chapter 5!

5. Care and maintenance

When carrying out care- and maintenance work, the “basic instructions“ in this operating manual (see Chapt. 2) must be followed



DANGER!

Risk of injury! The table saw must be switched OFF when carrying out care- and maintenance work!



ATTENTION

Disconnect the table saw from the main power supply and secure against unintentional restarting!



Before starting maintenance- and cleaning work, the table saw must be disconnected from the main power supply!

- Place the table saw onto a straight, horizontal ground with sufficient room around the CTS•26, L, XL to be able to carry out care- and maintenance work!



ATTENTION

According to the stipulated cycles in table 5.7.1 “care- and maintenance work“ and section 5.8, the maintenance- and care work has to be carried out!

Check the wear parts not subject to maintenance intervals for wear and tear and, if necessary, exchange!



Note:

Keep precisely to the care- and maintenance intervals and have the work carried out by a specialized worker or by CEDIMA®! This will prolong the working life of the table saw!



ATTENTION

Only use original parts!

Only be using original parts is the operating safety of the table saw guaranteed!

5.1 Cleaning

The table saw must be cleaned after each use and before each repair, maintenance work!

5.1.1 Cleaning agents



ATTENTION

Do not use any aggressive cleaning agents!

Aggressive cleaning agents such as solvents, acids as well as cleaning with fluids that resach a temperature of 30 °C are not allowed!



ATTENTION

Do not use any high -pressure, steam cleaners!

For safety -and functional reasons, make sure that no water, cleaning agents or steam penetrates the electric motors, the electronics, switches, plug connections e.g. as well as the bearings!

5.1.2 Dry cleaning

- Use lint-free cloth.
- Remove dust and dirt with a slightly dampened cloth.
- Remove stubborn residue with a, not too hard, brush.
- Blow through the protective grating of the air vent and so the radiator fins of the electric motor with compressed air!

5.1.3 Wet cleaning

- Before wet-cleaning, protect all plug connections with respective lids against penetrating of moisture.
- At most, remove residue and dirt with a soft jet of water and a brush.
- Take special care at critical places (switches, electric motor, ...)!
Electric motors, as well switches may not be subjected to the water jet!

Electric motors, as well switches may not be subjected to the water jet!

- Do not rinse the bearings to avoid the risk of them running dry! The bearings of the table saw are lubricated for life!
- After cleaning, remove all protective covers and sealing material!

**ATTENTION**

Before restarting, connect the table saw to a mains power point with integrated fault current circuit breaker (FI)! If the FI cuts the power supply, the table saw must be inspected by an electrician prior to restarting!

If necessary, let the table saw dry out and/or dry with compressed air!

5.2 Visual checks**ATTENTION**

The warning -and safety signs attached to the table saw must always be kept clean, so that they remain legible even after a prolonged time!

- Damage of operating elements, diodes, sockets resp. plugs, connections and/or electric motors and electronics (if installed), the mechanical system, ...!
- Switch OFF the machine immediately you notice any of the above mentioned damages! The table saw must be repaired in a specialized workshop or by CEDIMA®!

**DANGER!**

Risk of injury! It is not allowed to carry on working with the table saw as long as the before mentioned damages have not been repaired!

Work on electrics or electronics may only be carried out by a specialized electrician!

- Check all connections and connecting elements (blade guard, handles, ...)!
- Retighten all eventually loosened (screw) connections!

5.3 Re-greasing, corrosion protection

- The CTS•26, L, XL is, to great extent, protected against corrosion. After cleaning and after a longer standstill, supply the metallic sliding parts (roller table, guide) with a thin film of grease rep. corrosion protection oil.
All other mechanical bearings and movable machine elements should never run dry but

greased (sparingly) with multi-purpose grease and machine oil!

**ATTENTION**

Do not grease the guide rail!

The guide rail must not be greased or oiled as adhesive slurry and/or dust will lead to wear or damage to the guide rail and bearings!

**Note:**

Excessive greasing and oiling will lead to further wear due to adhering dust and cutting slurry!

5.4 Blade drive motor

- The blade drive motor does not require any special servicing! Clean the van-grid and the motor housing (radiator fin)
- Keep to the safety- and functional checks!

**ATTENTION**

Any eventual repairs must be carried out by a specialized electrician (special workshop) or by CEDIMA®!

5.5 Water pump

The, as an immersion pump designed, water pump is, to a large extent, maintenance free!
- Keep to the safety- and maintenance checks!

Pay attention to sect. 5.8.2!

5.6 Safety checks of the electric system according to BGV A3 §5, implementing regulations sec. 1 no 2

Table 1A: repetitive checks of stationary electric systems and operating elements

System / operating element	Time limit	Kind of checks	Inspector
Electric devices and stationary operating elements	4 years	for correct condition	Specialized electrician
Electric systems and stationary electric systems in “operatingsupplies rooms and devices of a special kind“ (DIN VDE 0100 group 700)	1 Jahr		
Protective measures with fault currency and fault voltage protection systems	1 month	For effectiveness	Specialized electrician or an electro-technical person using suitable measuring -and measuring devices
Fault current, differential current and fault- voltage switch (circuit breaker) - In stationary systems - In non- stationary systems	6 month working daily	For correct functioning when operating the testing equipment	operator

Table 5.1
Table 1B: repetitive checks in non-stationary electric systems and operating elementsl

System / operating element	Time limit, maximal approx. values	Kind of check	Inspector
- Stationary electric operating elements (if used) - Extension and appliance coupler with plug connection - Attachment line with plug - movable lines with plug and fixed connection	Approx. value 6 month, on building sites 3 month *). Should a fault (error) rate reach a range of < 2 %, the inspection time can be extended Maximal values: At building sites , in production- an under similar conditions one year in offices or under similar connections 2 years.	For correct condition	Qualified electrician using suitable mesuring -and testing devices, also electrically trained persons

Table 5.2

*) To concretise, see the BG information “selecting and operating the system and operating materials on building sites“ (BGI 608).

Table saw CTS-26, L, XL



5.7 Maintenance of the CEDIMA® table saw CTS-26, L, XL

5.7.1 Maintenance intervals

	Before each start	After finishing work	Work daily	After 30 working hours (weekly)	Monthly	after 3 - 6 Month	Yearly	On Disturbances	When damaged
Entire machine	3	1					3	3	4*
Electrical system	3	1	7	7	7	7	7	3	4
Tool (Diamond saw blade)	3, 6	1						3	4
Tool receptacle (Flanges and blades, ...)	1, 2	1						3	4
Guides	3	1, 2							4
Guide rollers	3				5				4
Swivel cutting head final stops (end-, deep, ...), -spring	3, 5	1		5				3, 4	4*
Operating elements (Switches, handles, ...)	3	1		5				3, 4	4
Water guiding (hoses, water container, -bucket, ...)	3, 2	1		3			3	3, 4	4
Accessories (auxiliary table, ...)	3	1						3, 4*	4
Water pump	3	1						1, 3, 4	4
Motor housing	3	1						3	4*
Motor (blade drive)	3, 7							3, 4*	3, 4
Reachable nuts and screws	3, 2			5					4*

1 Cleaning, draining

4 Changing, exchanging

7 Legally binding safety checks (see sect. 5.6)

*****) Depending on extent of damage

2 Lubricating, greasing, oiling, corrosion protection

5 Adjusting, retightening, exchanging wear parts

3 Checks (optical, functional)

6 Changing when necessary



You will find the description of the maintenance work in the following appropriate chapters in this operating manual!



The table may be actualised at any time by CEDIMA® (e.g. respective technical necessities and developments). Obtain information from CEDIMA®!

5.8 Cleaning- and maintenance work



ATTENTION

Pay attention to the safety instruction in this operating manual!

5.8.1 Cleaning the table saw

The table saw must be cleaned after each working session and before each maintenance- and repair work:

- To clean the water bucket, remove the roller table. The roller table is hinged one- sided to the frame (Fig. 5.1) and can be removed without the need of tools.

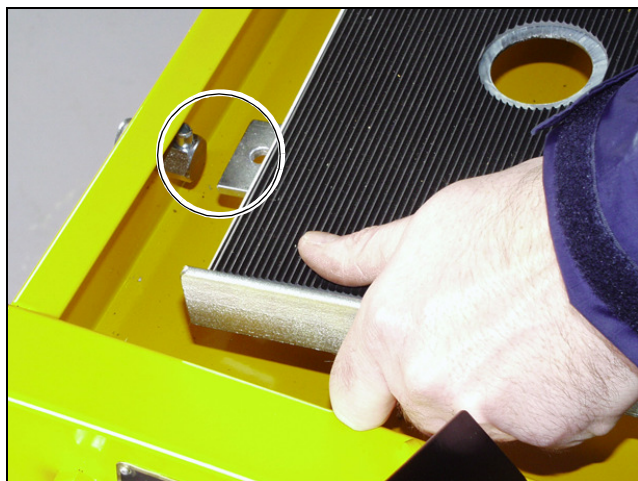

Fig. 5.1 Receptacle of the work table

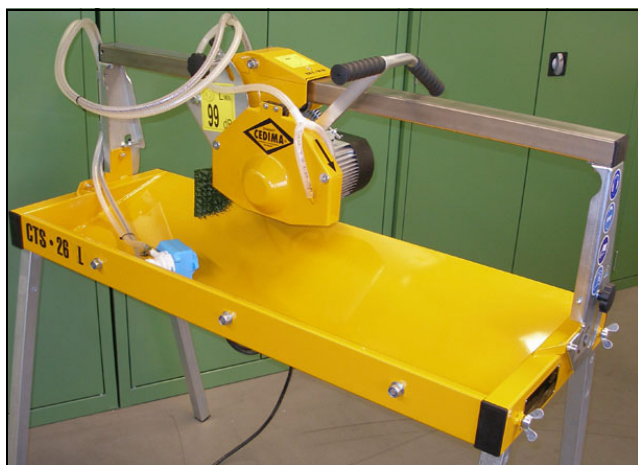

Fig. 5.2 CTS-26 L without work table

- dirty water and slurry must be removed from the water container/bucket (rinse out).

- Clean the pump sieve (filter) of the immersion pump. Rinse the immersion pump with clear water to avoid blocking of the pump due to slurry residue (see sect. 5.8.2).
- At the danger of frost, empty the cooling water system completely.
- Before longer period of stand-still, lightly grease all movable parts with the exception of the guide rail.

5.8.2 Cleaning the immersion pump

At longer periods of stand-still, it might be that hard-packed dirt has build up in the immersion pump and blocked up the pump wheel. When switching on the table saw, the blocked pump would be destroyed within a few minutes due to overheating. To remove such blockage, the pump sieve and the lid of the pump must be removed (Fig. 5.3 and 5.4).



Fig. 5.3 Immersion pump

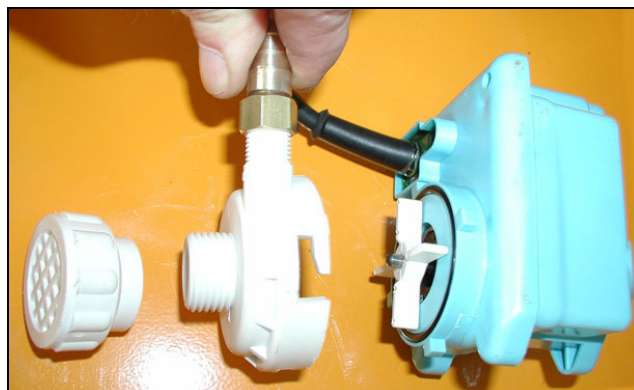

Fig. 5.4 Sieve and lid of the immersion pump demounted

To open and clean the immersion pump, carry on as follows:

1. Unscrew the pump sieve (filter) from the pump lid!
2. Lift the pump lid off the pump! For that, turn the pump lid so far to the left until the holder on the holder on the pump body has been released. Now lift off the pump lid (bayonet coupling, Fig. 5.4)!
3. Rinse and clean the lid of the pump and the pump sieve!
4. Remove the residue from the pump wheel (do not damage the rubber seal in the pump-housing, Fig. 5.4)!
5. Check for easy running of the pump wheel!
6. Push the lid of the pump back over the holder on the pump body and push so far towards the right, that the lid is securely (tightly) fitted (Fig. 5.3)!
7. Screw the sieve back on!
8. Place the immersion pump back into the water container/bucket (at least the suction sieve must be beneath the water level) and check the pump for function!

5.8.3 Cleaning the blade drive motor

There is a danger that slurry has build up around the housing of the blade drive motor forming a “plating” around it and in front of the air vent of the motor, so blocking the necessary heat dissipation. The blade drive motor switches itself OFF after a short time (overload protection, see sect. 4.3)!

See to free cooling ribs on the blade drive motor housing and free air vent (wipe out and blow through with compressed air, Fig. 5.5)!

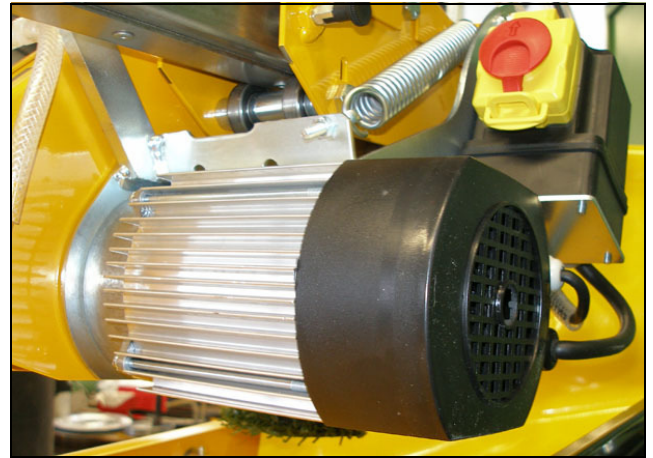

Fig. 5.5 „Clean“ blade drive motor

5.8.4 Cleaning the guide rail, swivel cutting head bearings

After prolonged operation, there is the danger that slurry residue has build up as a “plating” around the guide rail and the bearing of the swivel cutting head, so hindering movement of the swivel cutting head! This makes moving the swivel cutting head unnecessarily difficult

Make sure of a free guide rail and free bearings on the swivel cutting head (wipe off, brush off, Fig. 5.6 and 5.9).



Fig. 5.6 „Clean“ guide rail and swivel cutting head (underside, bottom)

Note:

The operational set-up of the table saw could be changed due to transport influences, possibly by screws on the swivel cutting head becoming loose or due to prolonged operations, so that a new basic adjustment might be necessary!

To reach the precision cuts, the table saw CTS•26, L, XL has been equipped with the following described set-up possibilities. Adjusting needs specialized knowledge and experience, so we recommend having the adjustments described in the following carried out in a specialized workshop or by **CEDIMA®**!

5.8.5 Adjusting the top bearings on the guide carriage

After demounting the cover plate (Fig. 5.7), both top bearings are reachable. Each bearing is placed on an eccentric, so that it can be individually and playfree advanced (fed) against the guide rail. Doing this lifts the position of the swivel cutting head into its optimal position.

1. Demount the cover panel!



Fig. 5.7 2 fastening screws on the cover panel of the guide carriage

2. Loosen the M10 holding screws of the bearings slightly (Fig. 5.8)!

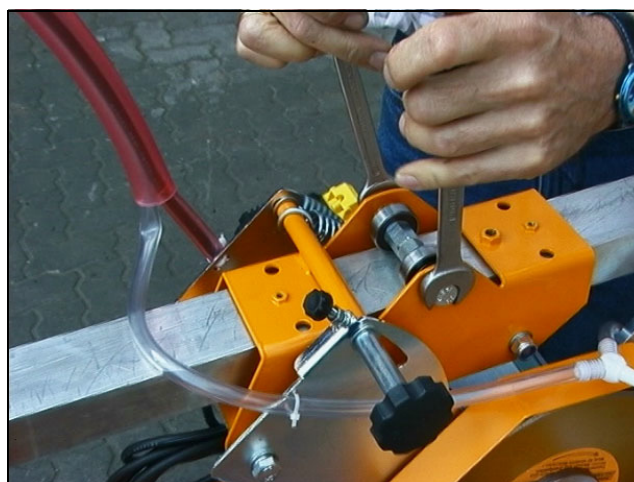

Fig. 5.8 Loosening the holding screws of the bearings

3. Turn the eccentric with the 2 WS 17 spanners until the guide carriage runs without play (Fig. 5.9)! To do that, move the guide carriage (the swivel cutting head) to -and- fro and check also if the 4 bearings underneath run without play on the guide rail (Fig. 5.6)!

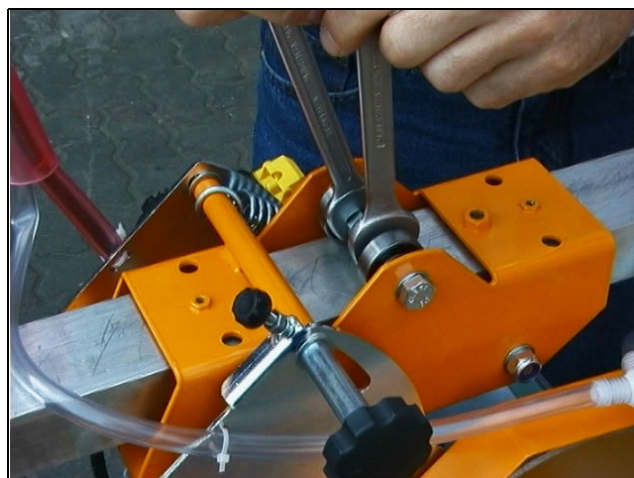

Fig. 5.9 Eccentric twisted

4. Tighten the M10 holding screws (Fig. 5.8)!
5. Remount the cover plate (Fig. 5.7)!

5.8.6 Adjusting the bottom bearings on the guide carriage

The guide carriage must run without play and smoothly on the guide rail. The direction of the thrust is given by the precise position of the straightedge which runs underneath the guide rail (Fig. 5.6)!

The bottom bearings are screwed down axial against the straightedge, so that all bearings can run along the straightedge without play (Fig. 5.6).

5.8.7 Adjusting the saw blade parallel to the forward thrust

To carry out precision cuts, the saw blade must be aligned exactly in the direction of the thrust of the straightedge. For this, provide the screw on the depth swivel bearing on the blade side of the swivel cutting head with a slot (Fig. 5.10), so that the lower part of the swivel cutting head can be adjusted when the M 10 screw is loosened.

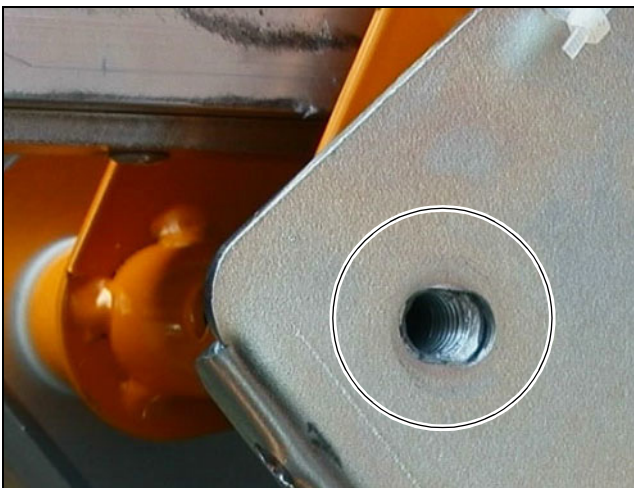

Fig. 5.10 Slot in the depth bearing (for better description screw removed)

To adjust the parallel line, a new diamond saw blade with a continuous edge is mounted. The swivel cutting head is lowered; a precise straightedge of about 50 cm is placed onto the worktable and pushed onto the frame (Fig. 5.11).

The saw has been adjusted precisely when, at thrust of the swivel cutting head, the saw blade runs along the straightedge. Should the saw blade run (during thrust movement) away from the straightedge, the swivel cutting head must be re-aligned again in thrust direction to the left-hand side, does the saw blade move the straightedge towards the right during cutting, the thrust direction must be aligned toward the right-hand side!



Fig. 5.11 Straightedge lined up

1. Mount a new saw blade with a through-running edge!
2. Put the swivel cutting head into the starting position
3. Place the straightedge parallel on to the saw blade (Fig. 5.11)!
4. Pull the swivel cutting head in to the feed direction, doing that, observe if and into which direction the saw blade runs away.
5. If necessary, loosen the M 10 screws of the swivel cutting head on the depth swivel joint and swivel the lower part of the swivel cutting head according to the above mentioned stipulations. In this connection, loosen the palm/star grip of the depth feed/advance (Fig. 5.12).



Fig. 5.12 Palm/star grip of the depth adjustment

6. For fine tuning, a M 6 nut has been attached to the steel construction. This place can be used for screwing in a M 6 x 25 screw (Fig. 5.13) for definite stop!

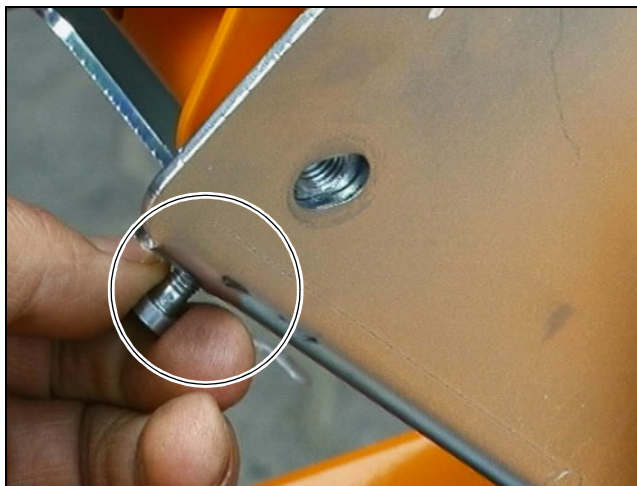

Fig. 5.13 M6 stop screw (not included in the delivery)

7. Readjust the M 10 screw on the depth swivel bearing (Fig. 5.14)!

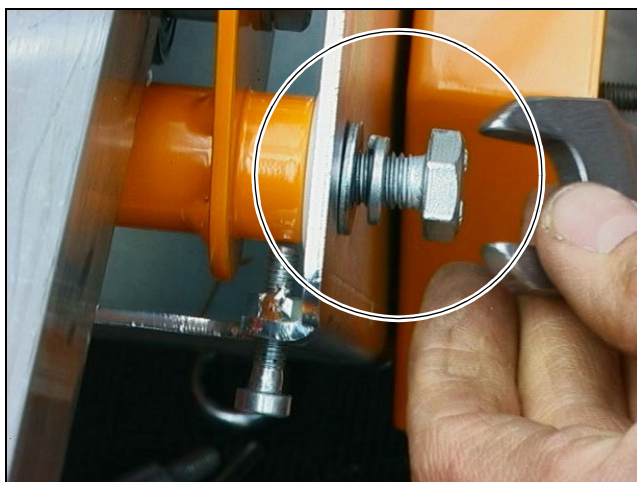

Fig. 5.14 M10 screw on the depth swivel arm tightened

8. Check the pushing movement again and, if necessary, readjust the saw blade until the saw blade runs smoothly along the straightedge!

5.8.8 Adjusting the end stop on the work table

You can check for the right angle between saw blade and end stop (lateral adjustable stop guide) on the roller table using a 90° angle stop. Four M 8 nuts resp. screws are positioned underneath the work table for attaching and adjusting. For adjusting, loosen the screws/nuts a little, so that half the stop can be moved by slight knocks with a hammer.

1. Slightly loosen the four M 8 holding screws e.g. the screws of the end stop (Fig. 5.15)!

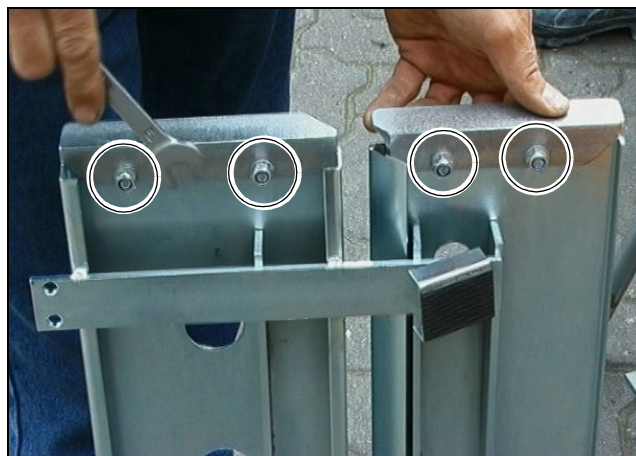

Fig. 5.15 M 8 fastening nuts of the end stop

2. Place a 90° angle between blade and end stop (Fig. 5.16)!

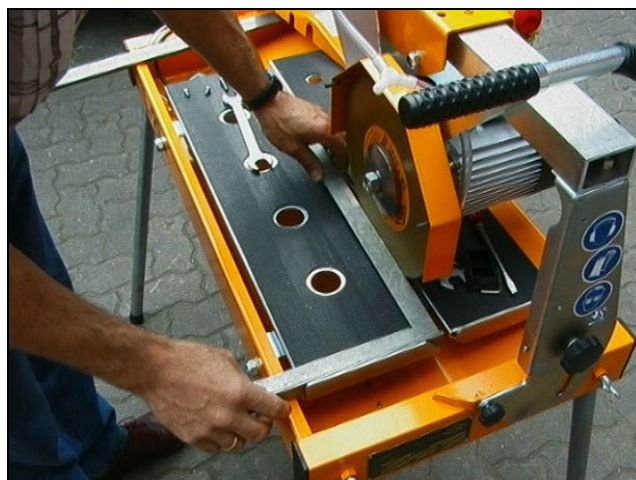

Fig. 5.16 Applying a 90° angle

3. If necessary, move the end stop using slight knocks with a hammer (Fig. 5.17)!



Fig. 5.17 Aligning the work table end stop

4. Retighten the M 8 screws and nuts (Fig. 5.18)!

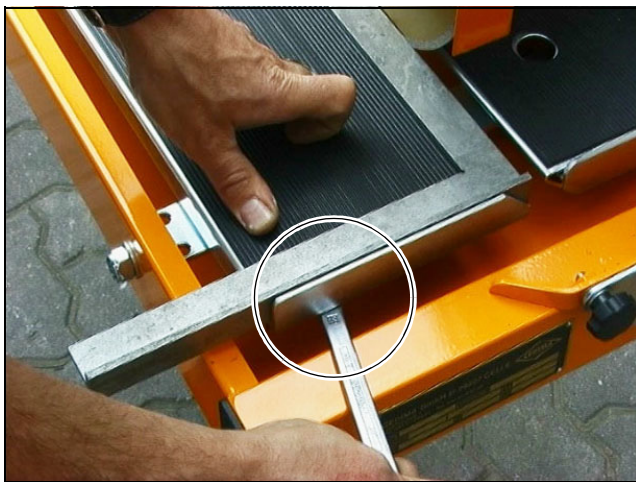

Fig. 5.18 Fastening the M 8 nuts/screws of the end stop

5.8.9 Correcting the 90° inclined cutting position

On the inside of both swivel plates, a hexagon socket set each as 90° angle is placed for adjusting inclined cuts (Fig. 5.19). If necessary, you can use this set screw to correct the 90° stop of the diagonal cutting. To do that, place a 90° angle stop on to the work table and push the angle on to the mounted new saw blade with continuous edge. The saw blade should be lying uniformly on the angle! After adjusting, retighten the jam nut!

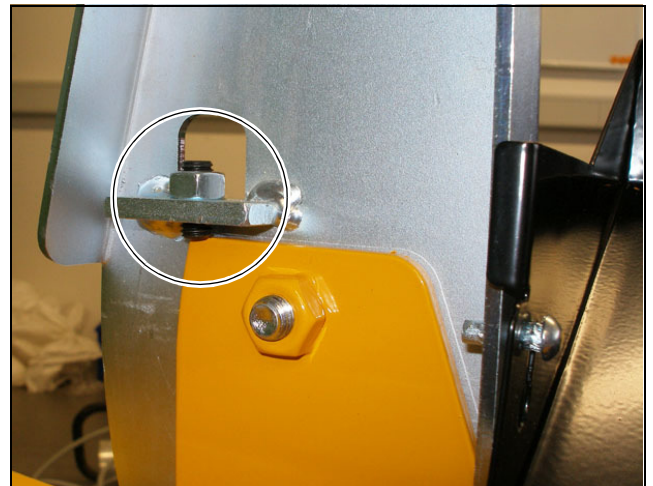

Fig. 5.19 90° stop of the diagonal cutting adjustment

5.8.10 Checking the centre of the blade adjustment

At normal - or bevel cuts, the saw blade should have sufficient room on both sides in the gap of the work table and run centred towards the M 8 screw on which the upper part of the machine swivels on its bearings (Fig. 5.20).

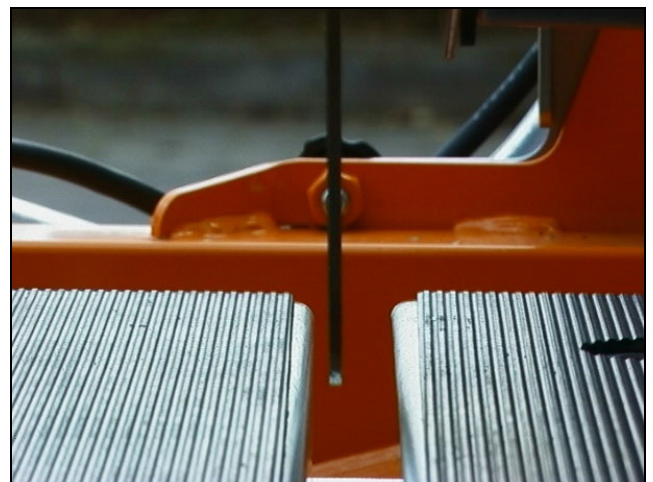

Fig. 5.20 Correct average values of the blade

Should the blade come too close to the steel parts of the work table, the upper part of the machine can become misadjusted when the fastening screws (Fig. 5.21 and 5.22) in between the guide rails and side plated become loosened! The guide rail could be moved for about +/- 2 mm in transverse direction, so that the swivel cutting head is pushed transversely compared to the work table!

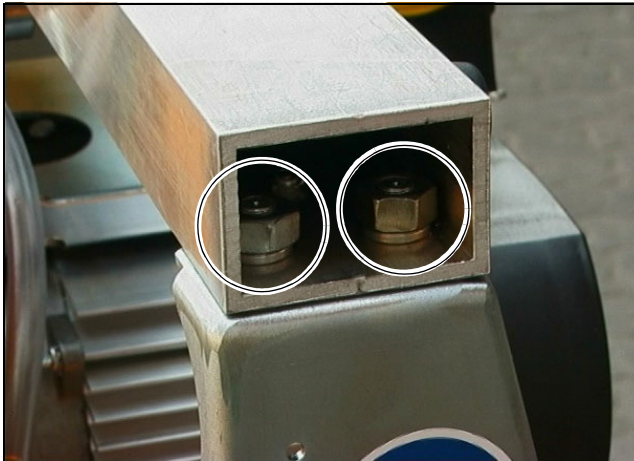

Fig. 5.21 Fastening screws of the guide rail (after removing the rubber cap)

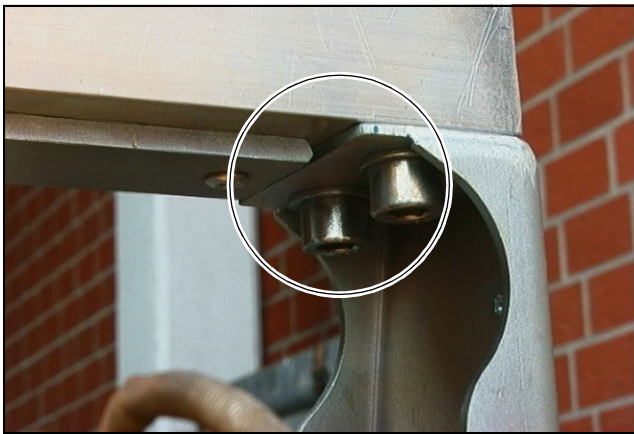

Fig. 5.22 Fastening screws of the guide rail (view from below)

In this CTS•26 series, the blade drive motor can also be moved transversely in slots with its fastening screws!

After these adjustment procedures, all other adjustment must be rechecked!

5.8.11 Set-up of the slide-in feet

The rubber feet of the work table are equipped with adjusting screws (Fig 5.23) in order to align the table horizontally and without shaking.



Fig. 5.23 Adjusting screw of an inserted table foot

After adjusting the work table, the 90° angle between the table top and the blade must be checked and, if necessary, readjusted (see sect. 5.8.9)!

5.8.12 Adjusting the swivel cutting head compensation spring

After loosening the clamping grip (Fig. 5.12), the weight of the swivel cutting head will be, for a large extent, accommodated by the respective compensation spring (Fig. 5.24). Consequently, in the cutting mode, (see sect. 4.2) only a fraction of the otherwise necessary power is needed to move the swivel cutting head up- and down. Adjust the spring tension by turning the nuts on the swivel cutting head (Fig. 5.24)!



Bild. 5.24 Adjustment possibilities of the swivel cutting head compensation spring



6. Transport and longer standstill times/storage

6.1 Transporting the table saw



ATTENTION

Always lock the guide carriage when transporting!

For transport, the guide rail must always be locked and secured with a locking device!

- Transport the table saw with the blade drive motor switched OFF (emergency-OFF button operated, table saw disconnected from the mains power supply/power supply plug pulled)!
- To avoid damage, demount the diamond saw blade!
- Empty the water container and the cooling system (keep the plug pulled)! Let the water container dry out!
- Lock the swivel cutting head and the pivoting arrangement of the cutting head!
- Demount the four slide-in feet and store them in the water container!
- Demount the splash guard (sheet) and store in the water container!
- If necessary, demount the upper section (guide rail with diagonal cutting adjustment and swivel cutting head, Fig. 1.2)!
- If necessary, demount the work table (Fig. 1.2)!
- Place the water pump and the mains power cable into the water container!
- Check the secure seating of all other components of the table saw!



ATTENTION

The complete table saw weighs about 58 kg and must be transported, according to the Accident Prevention - and Insurance Association Regulations, with transport vehicles! The upper part with the swivel cutting head is not designed for transport by crane

To transport the table saw, use a respective basket or tub!



Note:

After transport and completing set-up of the table saw, check all elements e.g. connecting elements for transport damage and secure seating!

6.2 Longer standing times, storage and winter operations

Standing times longer than 3 month:

- Disconnect the main power supply!
- Completely empty/clean the cooling -rinsing system (hoses, water pump, water container)!
- Clean the table saw and the accessories!
- Demount the diamond saw blade!
Clean the blade reception flange (cutting shaft, flange, ...)!
- Maintain and care for the table saw as in chapter 5!
- Relax the retaining spring of the swivel cutting head!
- Store the table saw in a dry, frost free room, protected against extreme sunlight, extreme temperature fluctuations, shocks and other physical and/or chemical influences!
- Turn the blade drive motor (cutting shaft) and the water pump for a few turns each month!
- At longer standing times, about 3-6 month, move all respective parts according to their function and put back into the respective storage positions!

At frost or temperatures under 0°C (winter operations):

By strong frost, drain the water (hoses, water-pump, water container, bucket, ...) after each operation to avoid freezing of the cooling system and eventual damages!

7. Trouble shooting

7.1 Problems concerning the table saw

Problem	Possible cause	Remedy
The table saw does not start after being switched on	Mains cable is not connected correctly	Check the mains cable connection
	The mains cable is defect	Exchange the mains cable
	The main (master) switch is defect	Have the mains (master) switch exchanged by a trained electrician
	The cable connections inside the table saw is defect	Have the cable connections checked/repared by a trained electrician
	The drive motor is defect	Have the drive motor exchanged by an trained electrician
The drive motor switches OFF	The cutting pressure is too high	Reduce the cutting pressure
	Wrong type of saw blade	Use the right type of saw blade
	Defects in the electric system	Have the drive motor exchanged and repaired by a trained electrician
	The motor housing is badly soiled	Clean the motor housing
The blade drive motor does not show any sufficient power	Loss of power due to too long electric power lines	Use shorter mains cable
	Loss of power due to the cable drum still wound up	Unwind the cable drum
	The power input of the local power supply system is insufficient	Pay attention and keep to the prescribed connecting data of the table saw
	The blade drive motor does not keep to the RPM	Have the motor checked, repaired and, if necessary exchanged by a trained electrician
	the blade drive motor is defect	Have the blade drive motor checked, repaired; and if necessary exchanged by a trained electrician
The blade drive motor runs, but the diamond saw blade stops when under load	The nut of the cutting shaft has become loose	Check, if necessary retighten the seat of the cutting shaft nut
The saw blade jams	The guide rail is delayed, stayed	Align and refasten the guide rail before swivelling and after swivelling (mitre cuts) on both ends



The saw blade touches the work piece bearing face (work table)	The swivel cutting head is lowered too far	Readjust/align the swivel cutting head (stop)
The cutting direction is not precisely aligned	the standard (bevel) cut (90°) is not at precise angle	adjust/align the stop of the swivel cutting head accordingly
Not sufficient or stopped cooling water supply	The water pump draws air	The immersion pump must at all times be completely covered by water. That way, the intake sieve (strainer) is in the respective position (water pump)
		Fill up with more water
	The intake sieve (strainer) of the immersion pump is blocked up	Clean the intake strainer of the immersion pump
	The pump wheel of the immersion pump is dirty	Open the immersion pump and clean it
	The immersion pump is without function	Have the electric supply cables to the immersion pump checked, repaired, exchanged by a trained electrician
	The water hoses are blocked, buckled, loosened or leaking	Check, align, connect or exchange the water hoses
	The immersion pump is defect	Have the immersion pump exchanged by an trained electrician

The problems and their possible causes result mostly from natural wear and in the **improper** use of the table saw resp. the diamond saw blades!

Therefore we recommend you to read this operating manual carefully!

Translation of the original operating manual 30001049 / 30001051 / UK 001

7.2 Problems when cutting

Problem	Possible cause	Remedy
The saw blade << wobbles >>	Poor saw blade tensioning	Return the saw blade to the manufacturer
The saw blade has lateral - and eccentric movement	The saw blade is damaged, bent	Have the saw blade aligned
		Solder the diamond segments onto a new saw blade
		Use a new saw blade
	The blade flange(s) are very dirty	Clean the blade flange(s)
	The blade flange(s) are defect	Exchange the blade flange(s)
	The cutting shaft is bent	Exchange the blade drive motor
The diamond segments become detached	The blade has overheated	Re- solder the diamond segments
		Optimise the cooling water input
The wear on the diamond segments are too high	Wrong type of saw blade	Use a harder type of saw blade
	The drive shaft runs untrue	Renew/exchange the blade drive motor
	The blade has overheated	Optimise the cooling water input
The saw blade does not cut	The saw blade is not matched to the material to be cut	Use the correct type of saw blade
	The saw blade is not suited to the machine performance	Use the right kind of saw blade
	The diamond saw blades are blunt	Sharpen the saw blade
The cutting performance is not optimal	Bad blade tensioning	Return the saw blade to the manufacturer
	The saw blade is loaded too much	Use the correct kind of saw blade
	The diamond segments are blunt	Sharpen the saw blade
The receiving bore of the saw blade has become wider due to wear	The saw blade has "turned" on the drive shaft	The centre hole in the saw blade must be turned out, so that a new (suitable) adaptor can be fitted
		Check the blade flange, if necessary, replace
The saw blade shows blooming colours	The blade has overheated	Optimise the cooling water supply
	Lateral friction when cutting	Reduce the feed
Cracks on (in) the saw blade	The saw blade is too hard	Use a "softer" saw blade
Eccentric wear on the Diamond segments	The saw blade receiving flange has shrunken	Have the receiving flange replaced
	Play on the bearings	Exchange the blade drive motor



8. Circuit diagram of the electrics

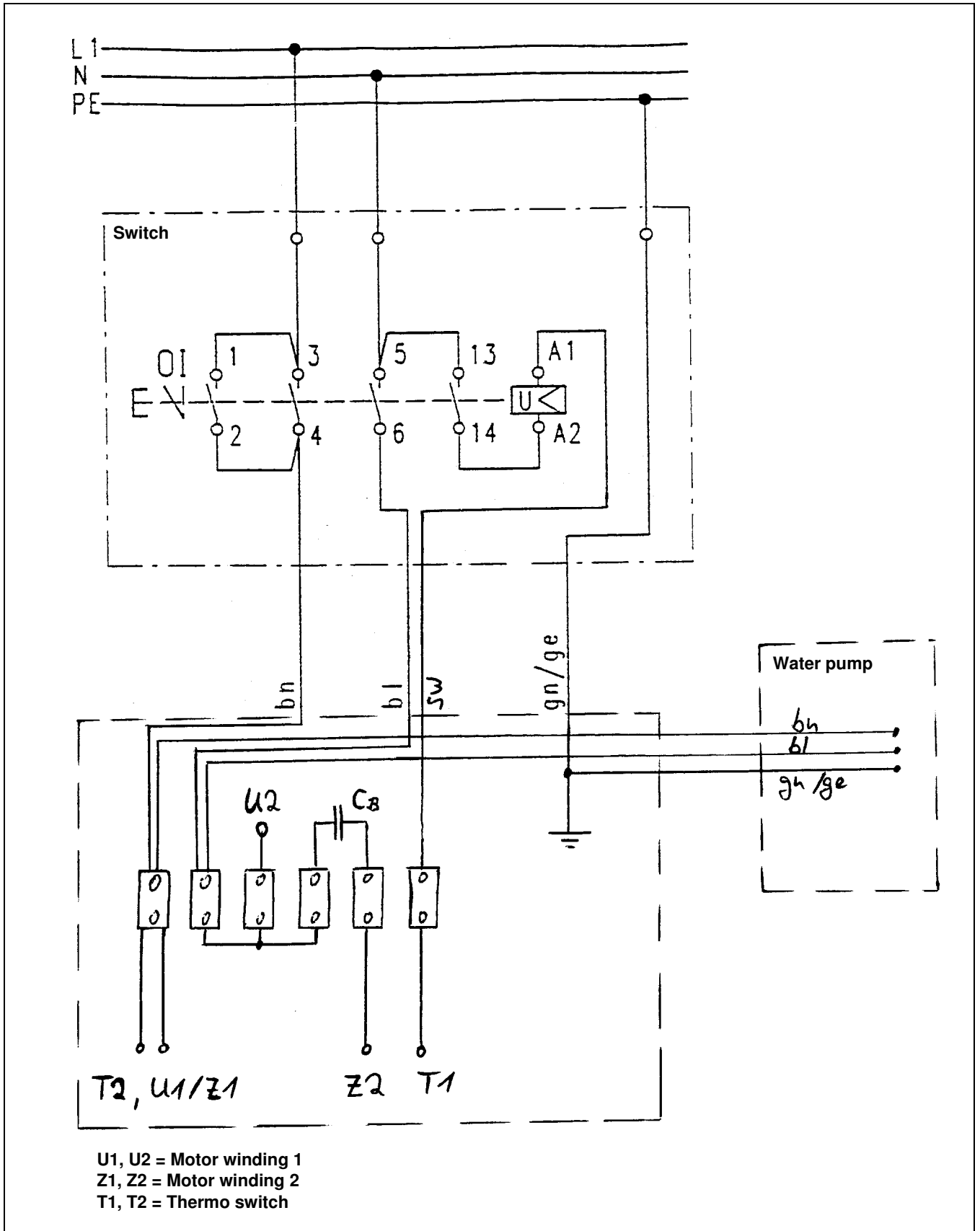

Fig. 8.1 Circuit diagram of the electrics of the CTS-26, L, XL (230 Volt-Version)

Translation of the original operating manual 30001049 / 30001051 / UK 001

9. Terms of Warranty

1. Complaints must be submitted without delay, however, within 14 days following the arrival of the device at the latest. If this deadline has expired, or if the device complained about is put into operation and used for work, then the device complained about shall be considered accepted and therefore free of faults. Hidden defects must be reported in writing immediately after being discovered, however at the latest within 6 months of the receipt of the device.
 2. We guarantee the agreed usability of the device delivered by us for a period of 12 months, the term beginning on the day the device arrives with the buyer. Irrespective of this, our obligation shall be considered as fulfilled, as soon as the goods are despatched from our works/warehouse. In no case do we assume a producer's guarantee. The mandatory regulations of the law for product liability remain untouched.
 3. Wearing parts are subject to a limited warranty. Wearing parts are parts subject to operation-related wear during proper use of the device. The rate of wear cannot be uniformly defined and differs according to the intensity of use. The wearing parts must be adjusted, maintained and, if necessary, replaced for the specific device in accordance with the manufacturer's operating manual. Operation-related wear is not a reason for claims to defects.
- Wearing parts for the construction devices such as core drilling and sawing machines and special machinery as well as related general assemblies (if available):
- Feed and drive elements such as toothed racks, gearwheels, pinions, spindles, spindle nuts, spindle bearings, wires, chains, sprockets, belts
 - Seals, cables, hoses, packings, gaskets, plugs, couplings and switches for pneumatic, hydraulic, water, electricity, fuel systems
 - Guide elements such as guide strips, guide bushes, guide rails, rollers,
 - bearings, sliding protection supports
 - Clamping elements for quick-release systems
 - Flushing head seals
 - Slide and roller bearings that do not run in an oil bath
 - Shaft oil seals and sealing elements
 - Friction and safety clutches, braking devices
 - Carbon brushes, collectors / armatures
 - Consumable operating materials such as fuels, lubricants, coolants etc.
 - Easy-release rings
 - Control potentiometers and manual switching elements
 - Securing elements such as dowels, anchors, screws and bolts
 - Fuses and lamps
 - Bowden cables
 - Commutators
 - Diaphragms
 - Spark plugs, glow plugs
 - Parts of the reversing starter such as the starting rope, starting pawl, starting roller and return spring
 - Sealing brushes, rubber seals, splash protection cloths
 - Filters of all kinds
 - Drive and guide wheels/pulleys and associated rubber tyres
 - Cable wire protection elements
 - Drive and travel wheels
 - Water pumps
 - Cut-material transport rollers
 - Drilling, separating and cutting tools
 - Energy storage devices.
4. In case of a justified complaint, we can choose to repair the device and/or to provide a replacement against return of the device. Replaced parts or devices become our property.



5. A complaint has to be filed in writing, stating machine number, invoice number and date.
6. Improvements shall always be carried out at the delivery plant. Repair work requested by the buyer to be carried out on his or a third party's premises, needs prior consent by us. The resulting costs of the mechanic and any other assistants are borne by the buyer. The warranty expires, if the customer or any other, unauthorized person, interfere with the purchased device.
7. If the replacement of assemblies or components by the buyer or others has been expressly arranged with us, any possible recognition of the warranty case cannot be given by us until after the defective parts have been returned to us and inspected by us.
8. According to the statutory regulations the buyer is only entitled to cancel a contract, if we refuse improvements or the supply of replacements acc. to fig. 4 even though a defect has been proven, or a deadline that we have been given has elapsed unfulfilled. If only a minor defect has occurred, the buyer is merely entitled to an abatement of the purchase price, which in any other case is excluded. We are not liable for compensation on account of a defect or damages subsequent to a defect, unless these occur on account of an intention or a negligence which we are responsible for.
9. No guarantee is assumed for damages that have arisen of the following reasons:
 - a) faulty installation,
 - b) improper use or overstressing,
 - c) permanent overload, leading to damages to coils or the windings of armatures,
 - d) extraneous causes, e.g. transport damages, climatic influences or other natural phenomena,
 - e) use of integral or accessory parts that are not suitable/adjusted to our devices.
10. If there is reason for complaint about a diamond tool(s), this tool(s) must be removed from the machine immediately! To protect your interest and to conduct a proper inspection, a segment height of at least 20 % (of height in new condition) is required. Failure to observe this will lead to any claims to replacement that you may have being voided!
11. If warranty claims are satisfied by us, then this neither extends the warranty period nor does it begin a new warranty period for the device. The warranty period for installed spare parts shall end no sooner or later than the warranty period for the device.
12. Otherwise, our complete terms of sale and delivery apply.
13. The place of performance and venue for both parties is Celle.

**CEDIMA® Diamantwerkzeug- und Maschinenbaugesellschaft mbH,
Celle, Germany**

January 2005



**Diamond saw blades • Diamond drill bits • Joint cutters • Core drill machines
Wall saws • Wire saws • Chain saws • Table saws • Reinforced concrete breakers**

CEDIMA[®] GmbH
Lärchenweg 3 • D-29227 Celle/Germany
Tel.: +49 (0) 51 41 / 88 54-0
Fax : +49 (0) 51 41 / 8 64 27
e-mail: info@cedima.com
internet: www.cedima.com