



Drill Rig B14

Date : 28-10-2020

Created : S. Pos

Revision:

791700X

Page 2 of 4

PARTS LIST

ITEM	QTY	PART NUMBER	DESCRIPTION	REVISION DATE
1	1	7980201	Grip (Assembly)	
2	2	FR020	Spring Retaining Ring	
3	2	FS20P3	Shimring	
4	1	7980022	Spindle	
5	2	ET019A	Bearing	
6	1	F1066	Spirit Level (Round)	
7	2	E4008B	O-Ring	
8	1	7980021	Clampring	
9	2	FBC020	Cylinder Head Cap Screw	
10	1	7981083	Carriage	
11	4	792301	Slide Block	
12	2	FI0610ST	Hexagon Socket Set Screw Soft Tip	
13	1	7980009	Adjusting Nut (Assembly)	
14	1	A5026	Spirit Level (Rectangle)	
15	1	7980023	Sliderblock Holder	
16	1	792209	Depth Indicator	
17	2	FF3630	Countersunk Flat Head Self-tapping Screw	
18	1	7980035	Endplate Column	
19	1	Y2043	Serial Plate	
20	1	Y2043A	Serial Protection	
21	1	7980040	Clamping Block	
22	1	7980155	Handle	
23	7	FS10	Washer	
24	1	7982006	Clamping Bolt	
25	1	G1101	Tool Kit	
26	4	FS10K1	Washer	
27	4	FB1022	Hexagon Head Screw	
28	2	7980039	Stabilisation Bar	
29	1	7980031	Column	
30	2	7980025	Hex Bolt	
31	1	FBC050	Cylinder Head Cap Screw	
32	1	UAB013	Logo Plate ADAMAS	
33	4	7980033	Adjustment Bolt M10 Self-Cleaning	
34	4	FM10	Hex Nut	
35	4	F42611	Pressure-ring	
36	1	7981081	Base	
37	1	7980026	Clamping Block	
38	2	FBE1220	Hexagon Socket Button Head Screw	
39	1	7980027	Column Stop	
40	1	NMH0140	Manual - ADAMAS - Instructions for use - B14	

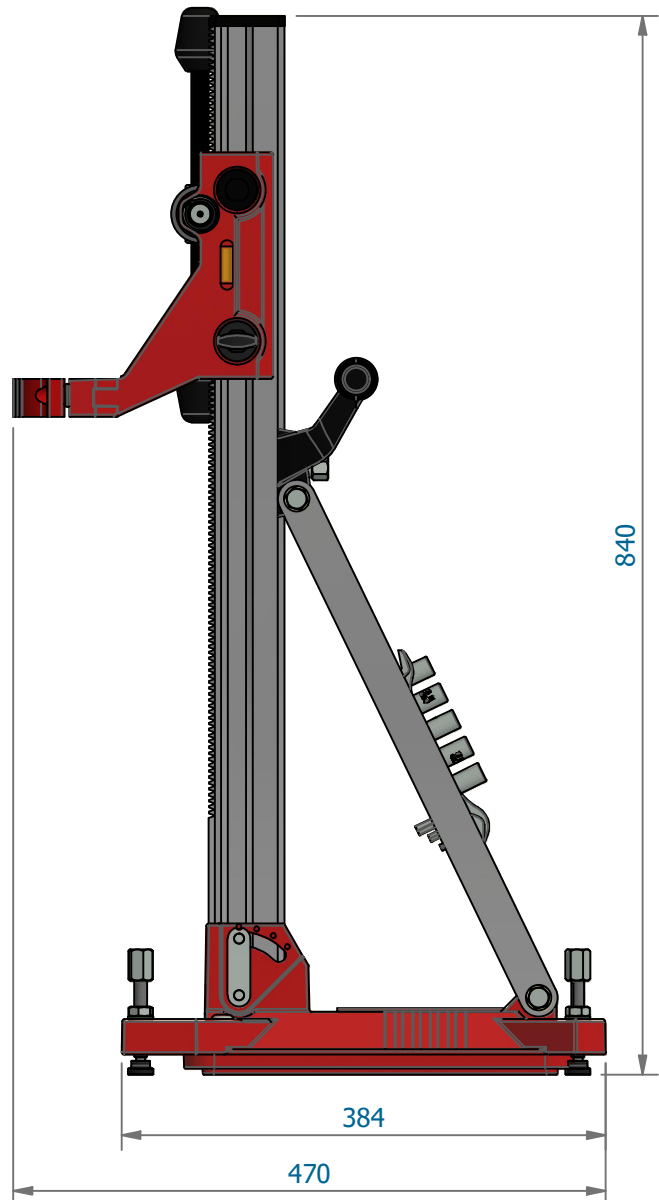
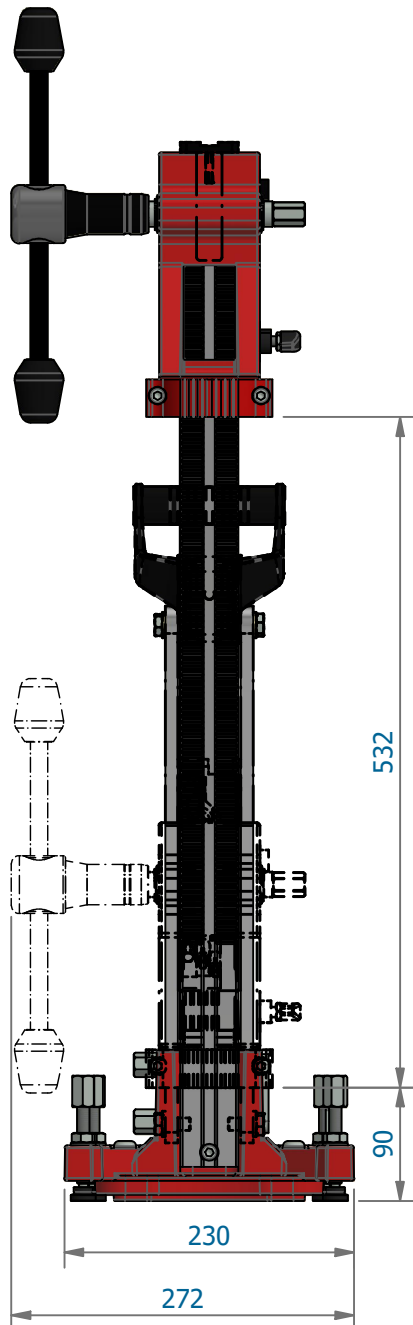
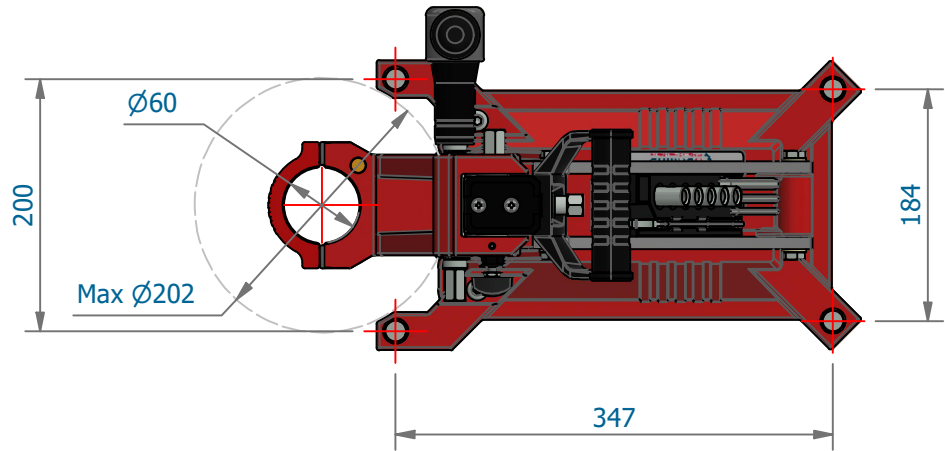

ACCESSORIES

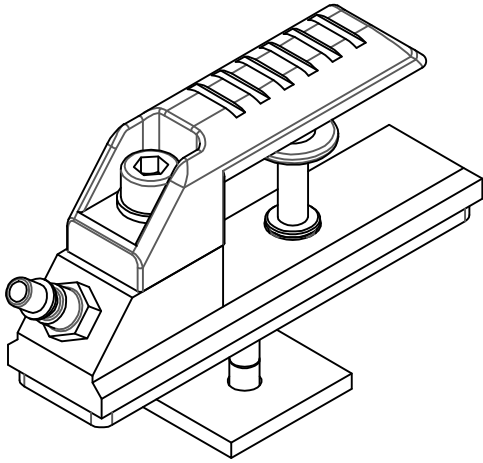
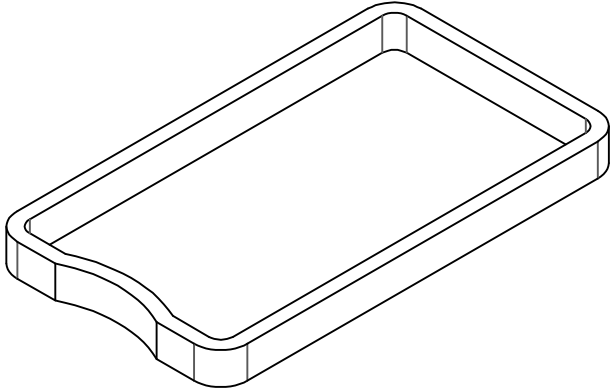
7980010	Vacuum Block (Assembly)	791521	Vacuum Rubber
			
7980146	Water Collector Ring Ø130mm	2PL14	Center Laser 113mm
